

# Explosion drawings & spare part list

**HansDampf 6.1**

**HansDampf 6.2**

**HansDampf 10.1**

**HansDampf 10.2**



PLATON SERVICE  
8 (800) 500-34-47  
www.platonservice.com

**soft water assembly group**  
**(HansDampf 6.1 / 6.2 / 10.1 / 10.2)**

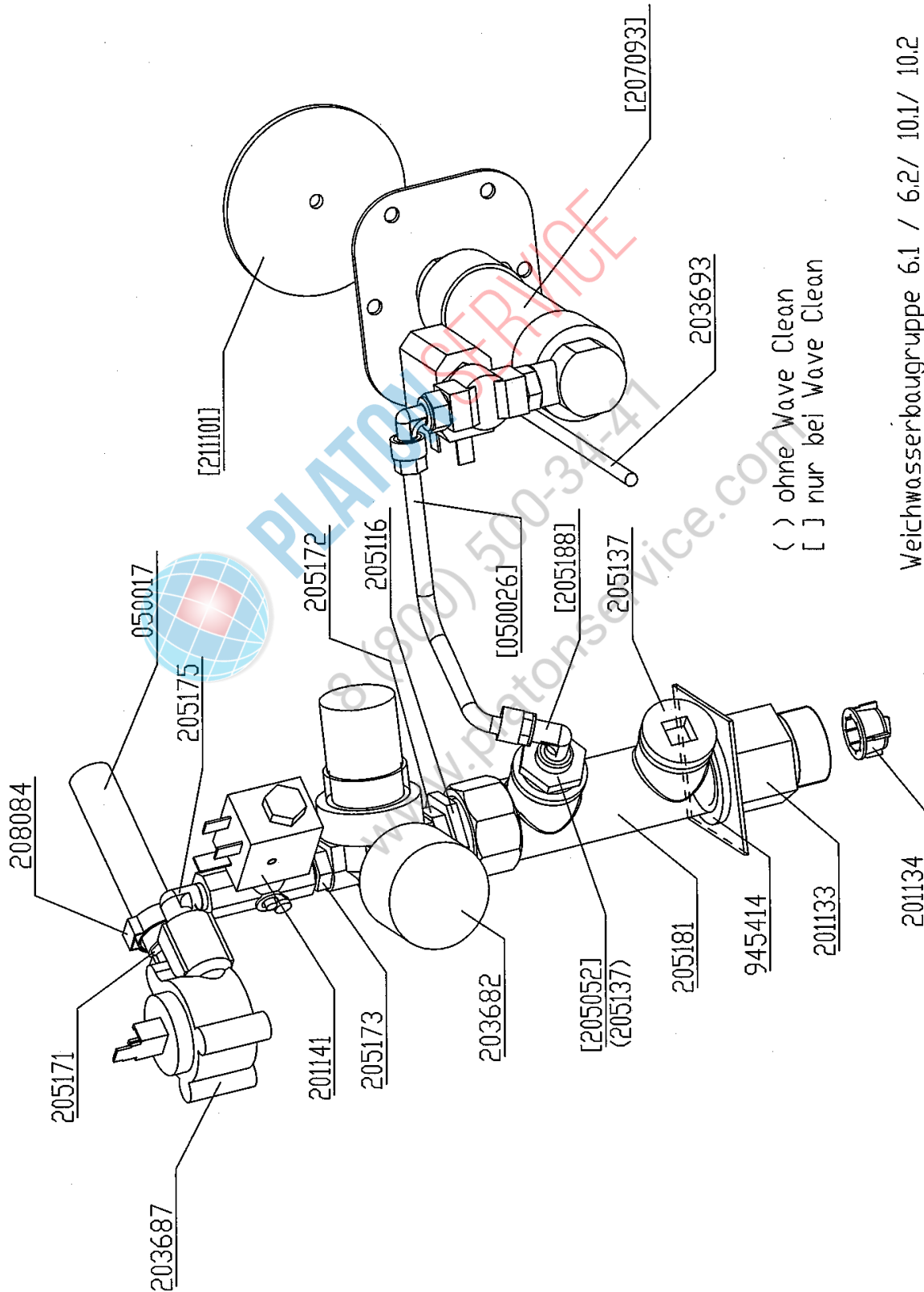

( ) ohne Wave Clean  
 [ ] nur bei Wave Clean

Weichwasserbaugruppe 6.1 / 6.2/ 10.1/ 10.2  
 mit Wave Clean  
 25.04.03 KE  
 69-01ZM05-D (-D/25.01.05 PN)

# cold water assembly group (HansDampf 6.1 / 6.2 / 10.1 / 10.2)

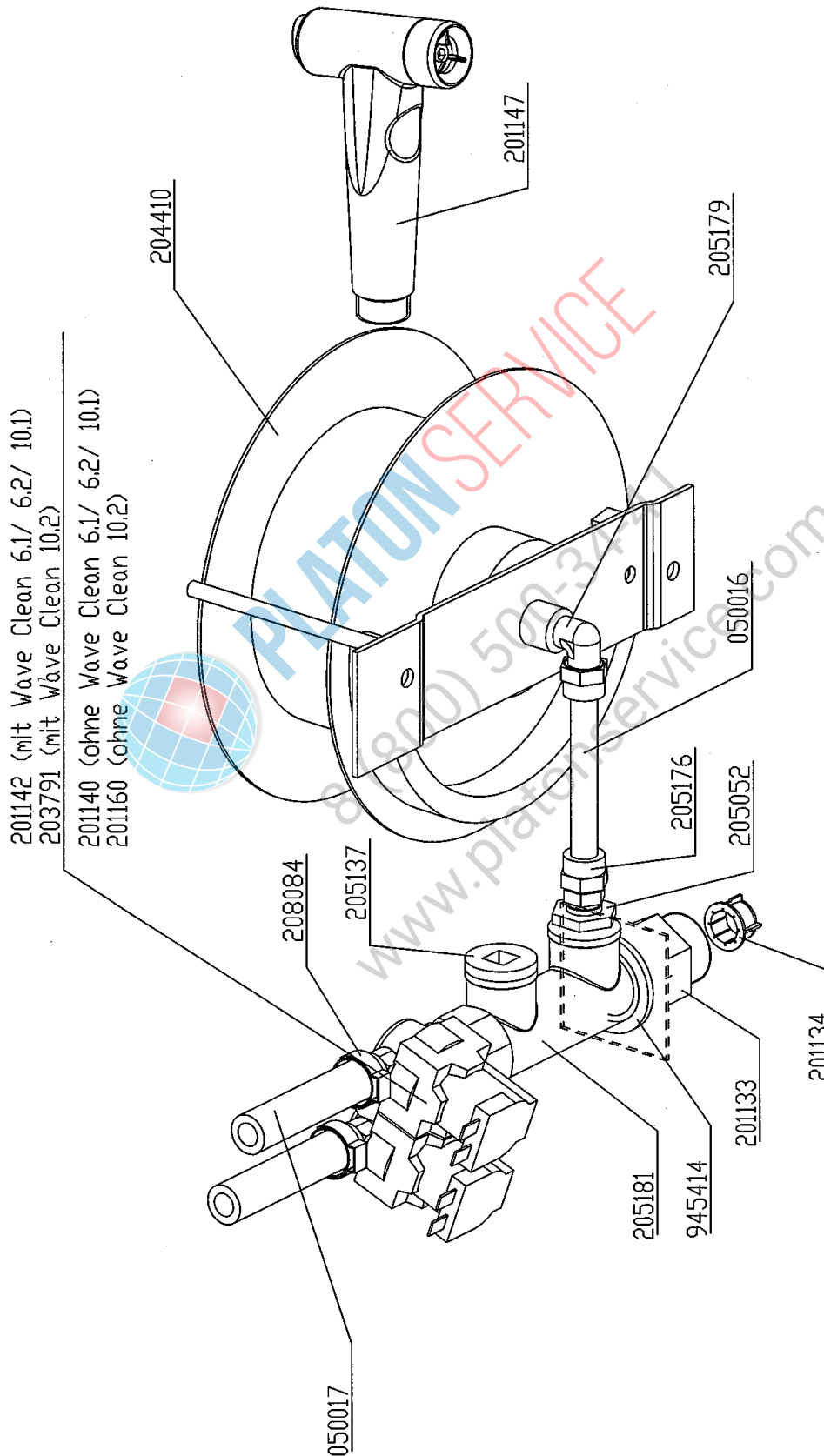

Hartwasserbaugruppe 6.1/ 10.1/ 6.2/ 10.2  
25.04.03 KE  
69-01ZM04-C (-C/25.01.05 PN)

### ventilation group (HansDampf 6.1 / 6.2 / 10.1 / 10.2)

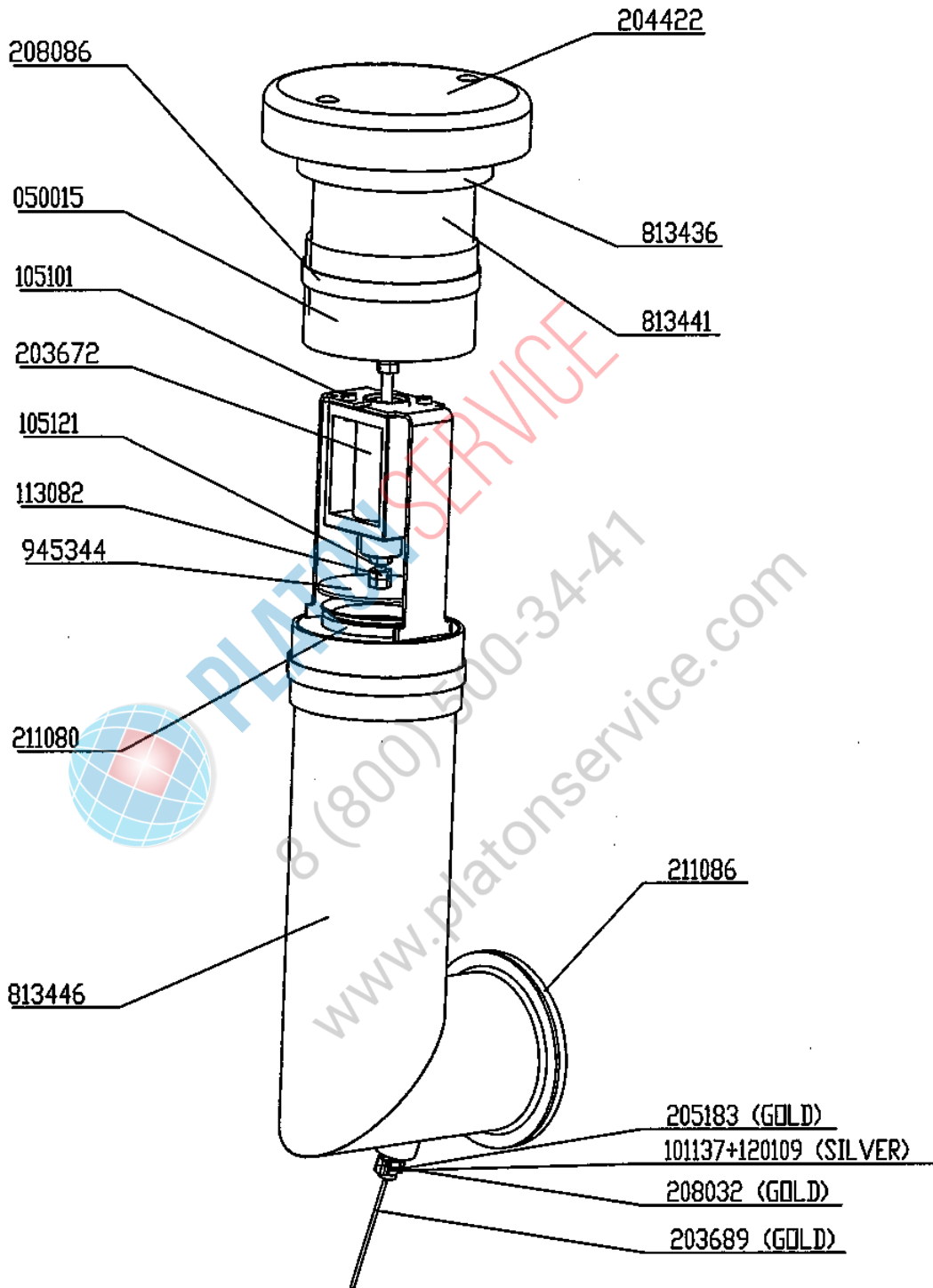

BELUEFTER 6.1/ 6.2/ 10.1/ 10.2  
28. 04. 03 PN  
69-01ZM06-A (-A/25.01.05 PN)

# motor / heating system

(HansDampf 6.1 / 6.2 / 10.1 / 10.2 / 20.1 / 20.2)

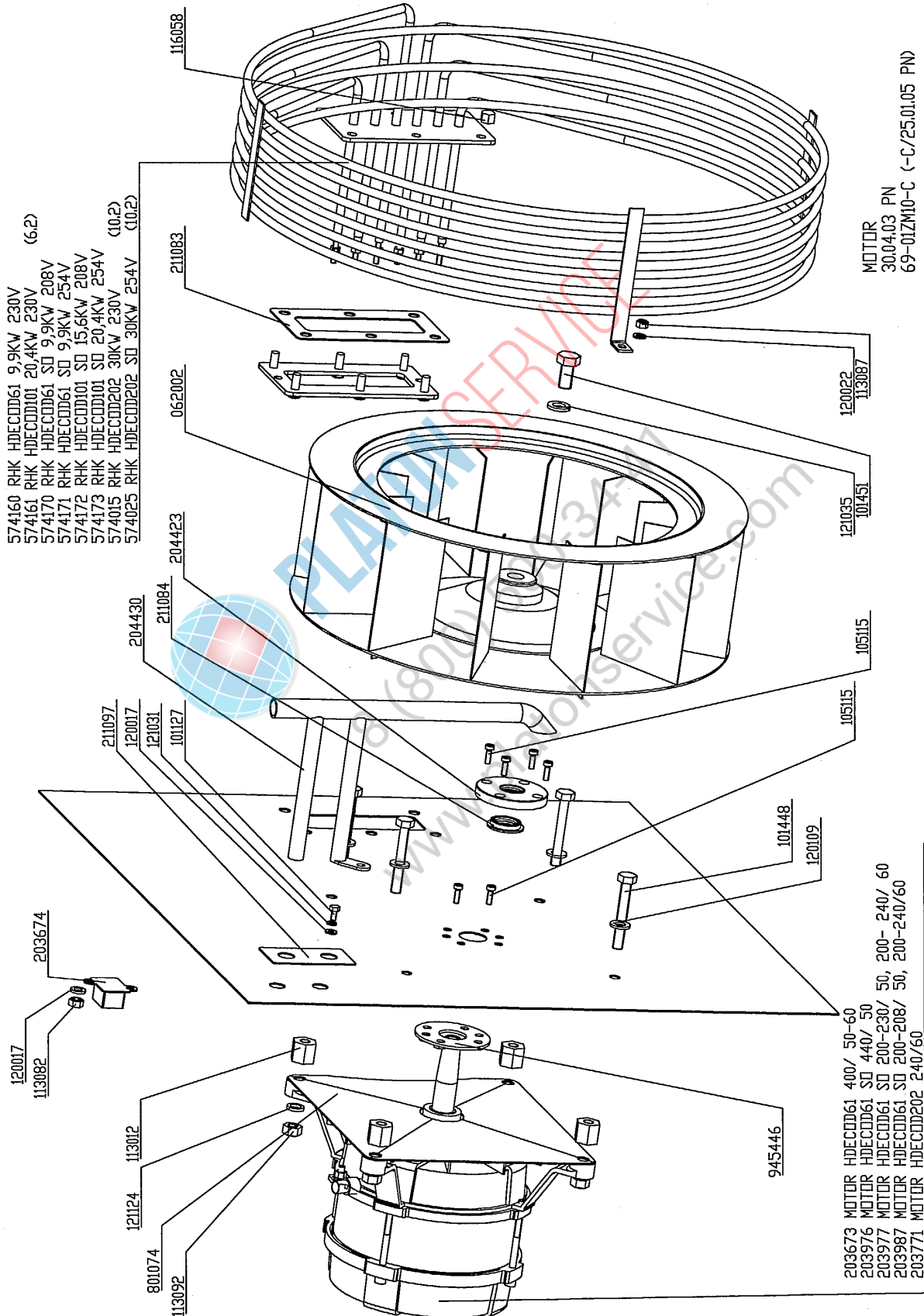

**electronic group (HansDampf 6.1 / 6.2 / 10.1 / 10.2)**

**version „with contactors“**

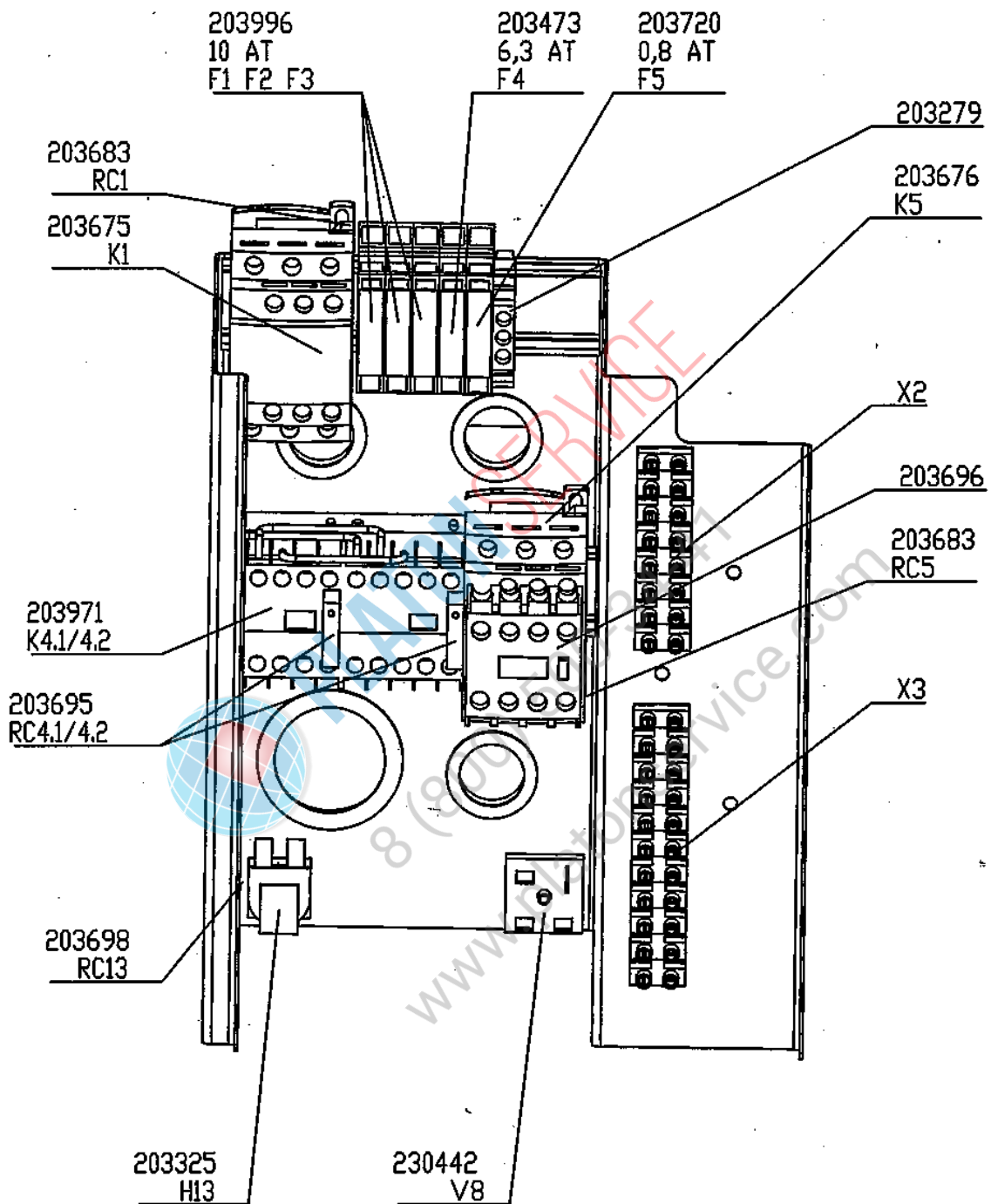

ELEKTROBAUGRUPPE 203736 6.1/10.1  
20.05.03 PN  
69-01ZM12-B (-B/ 3.02.05 PN)

# electronic group (HansDampf 6.1 / 6.2 / 10.1 / 10.2)

## frequency controlled version

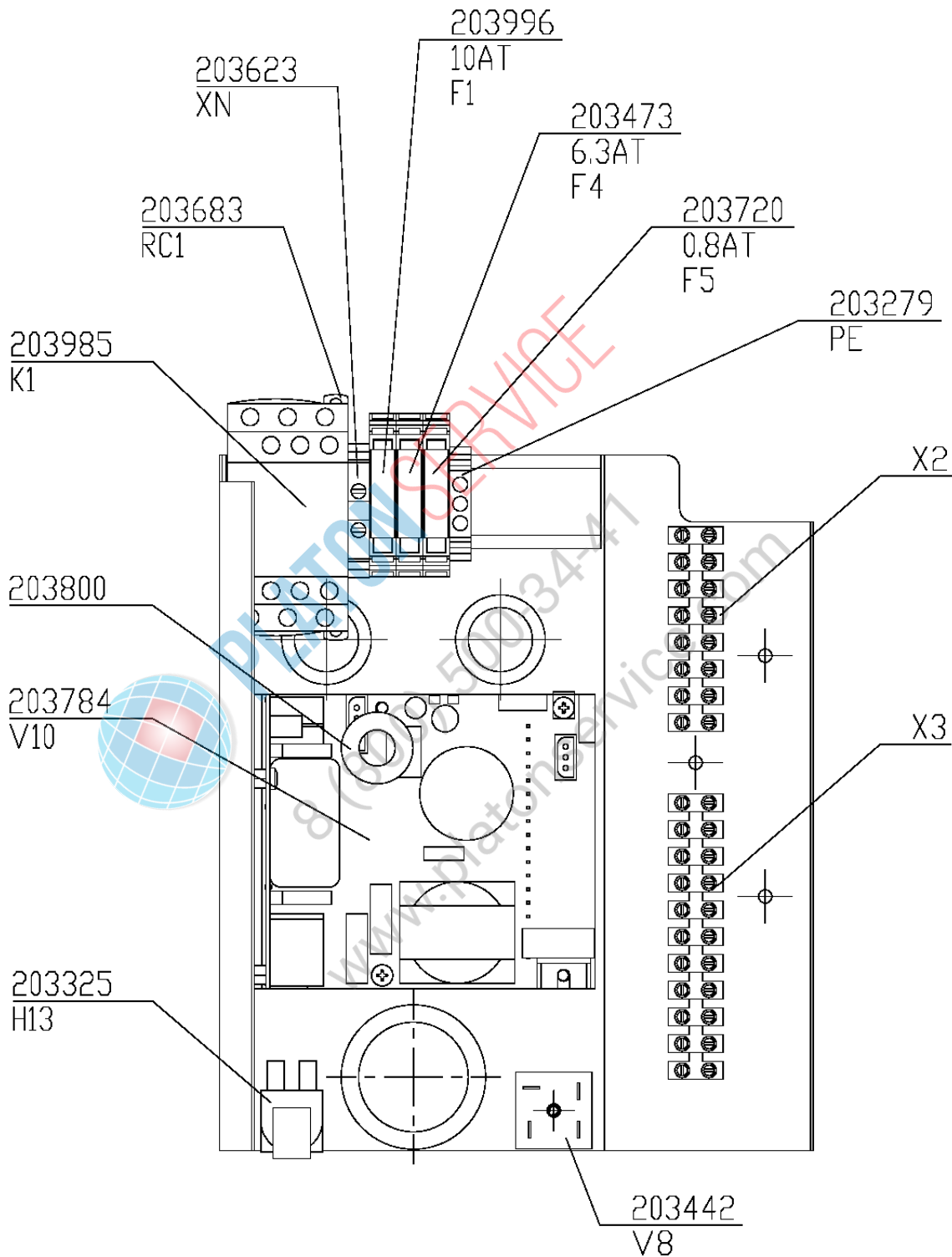

ELEKTROBAUGRUPPE 203983 6.X, 10.2  
22.03.05 KS  
69-01ZM19--

# front panel

(HansDampf 6.1, 6.2, 10.1, 10.2, ,20.1, 20.2)

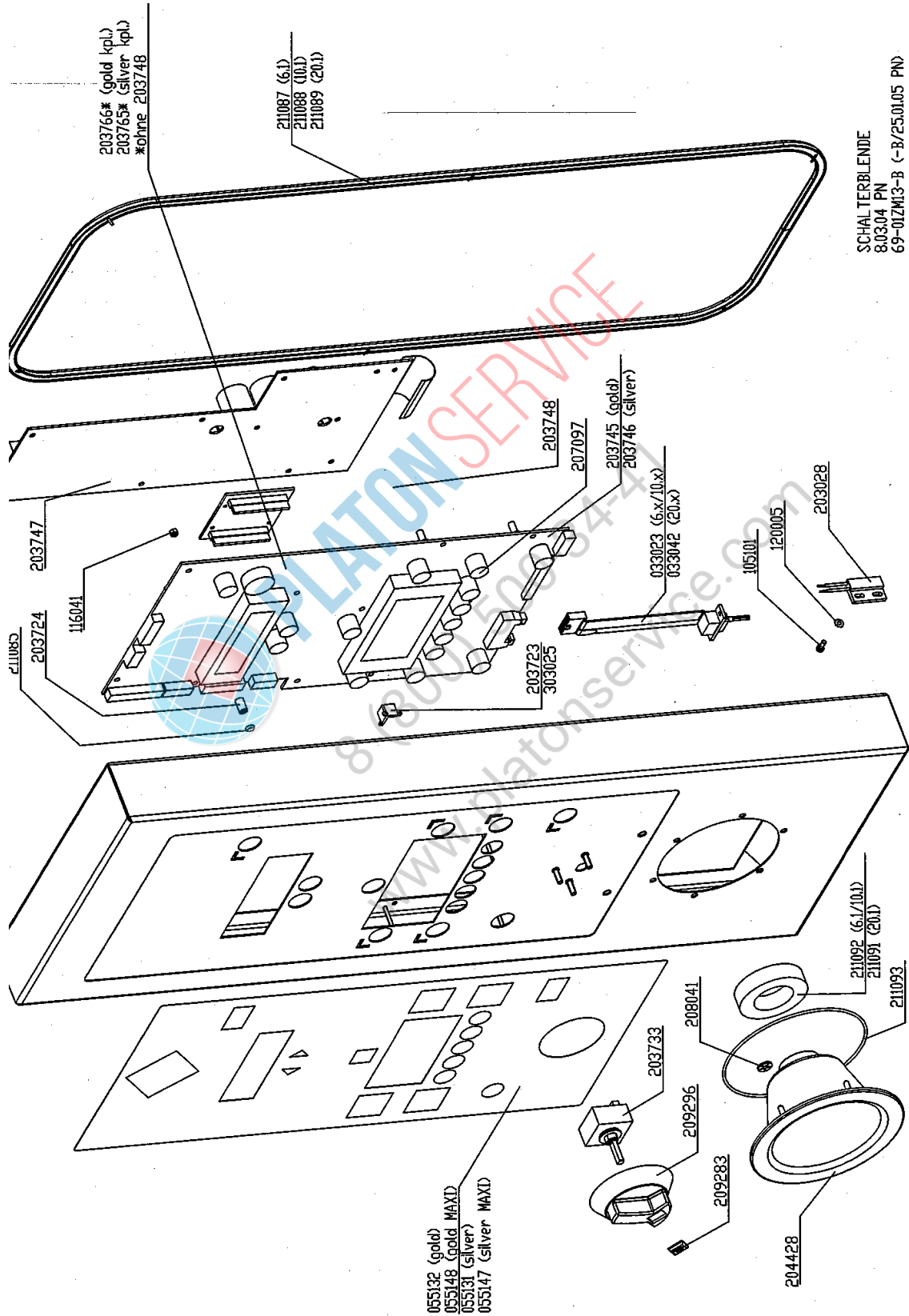



# appliance main view (HansDampf 6.1, 6.2, 10.1, 10.2, 20.1, 20.2)

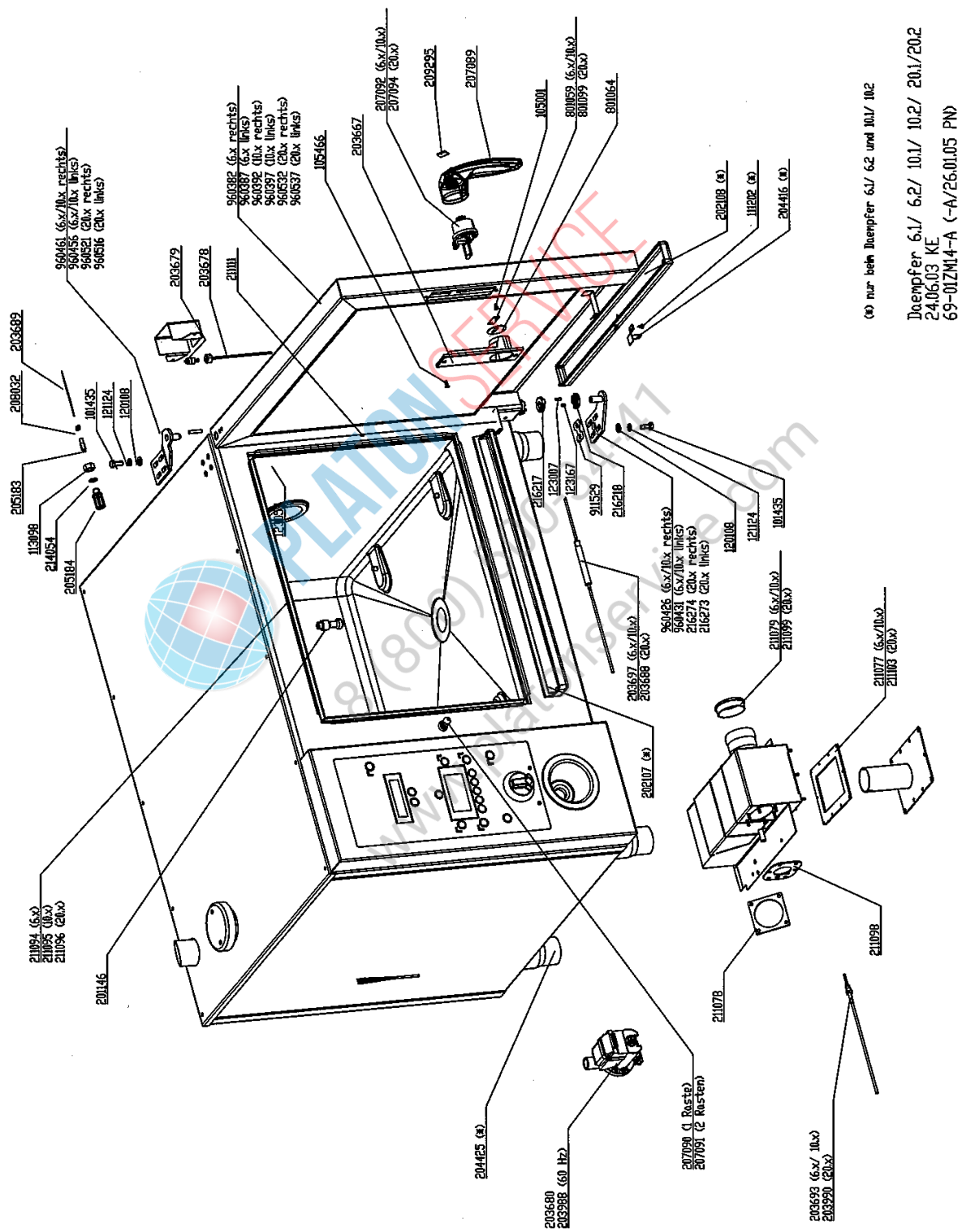

(\*) nur beim Baupfer 6.1/ 6.2 und 10.1/ 10.2  
Baupfer 6.1/ 6.2/ 10.1/ 10.2/ 20.1/ 20.2  
24.06.03 KE  
69-01ZM14-A (-A/25.01.05 PN)

## Spare part list HansDampf 6.1 / 6.2 / 10.1 / 10.2

Artikelnummer part number	Bezeichnung	part description
033023	Datenkabel	data cable
033042	Datenkabel	data cable
050015	Silikonschlauch	silicon hose
050016	Polyamid Schlauch	polyamide hose
050017	Silikonschlauch	silicon hose
050026	Polyamid Schlauch	polyamide hose
055131	Tastaturfolie	front laminate piece
055132	Tastaturfolie	front laminate piece
055147	Tastaturfolie	front laminate piece
055148	Tastaturfolie	front laminate piece
062002	Ventilatorrad	fan wheel
101127	Sechskantschraube M4 x 8	hexagon screw M4 x 8
101137	Schraube M8	screw M8
101435	Schraube 6KT M8 x 20	screw 6KT M8 x 20
101448	Sechskantschraube M8 x 54	hexagon screw M8 x 54
101451	Sechskantschraube M10 x 20	hexagon screw M10 x 20
105001	Linsenkopfschraube M4 x 8 + Federring	screw M4 x 8
105101	Zylinderkopfschraube M3 x 8	Cheese head screw M3 x 8
105115	Zylinderkopfschraube M4	Cheese head screw M4
105121	Schraube M4	screw M4
105466	Schraube M4 x 12	screw M4 x 12
111202	Schraube B3,9 x 9,5	screw B3,9 x 9,5
113012	Sechskantmutter M8	hexagon nut M8
113082	Sechskantmutter M4	hexagon nut M4
113087	Sechskantmutter M5	hexagon nut M5
113092	Sechskantmutter M8	hexagon nut M8
113098	Sechskantmutter M12	hexagon nut M12
116041	Sicherungsmutter M3	lock nut M3
116058	Hutmutter M6	cap nut M6
120005	Scheibe U3,2	washer U3,2
120017	Scheibe U4,3	washer U4,3
120022	Scheibe U5,3	washer U5,3
120108	Unterlegscheibe 8,4	washer U8,4
120109	Scheibe U8.4	washer U8.4
121031	Federring 4	spring washer 4
121035	Federring 10	spring washer 10
121124	Sicherungsscheibe M8	lock washer M8
123007	Stift 4 x 12	pin 4 x 12
123057	Stift 6 x 28	pin 6 x 28
123167	Stift 5 x 26	pin 5 x 26
201133	Hahnverlängerung R 3/4"	cock extension R 3/4"
201134	Wasserzulaufsieb	water inlet filter
201140	Magnetventil 0,3-10 bar 1,3L/min	magnetic valve 0,3-10 bar 1,3L/min
201141	Rückschlagventil	check valve
201142	Magnetventil 0,3-10 bar 1,3L/min	magnetic valve 0,3-10 bar 1,3L/min
201146	Duese Reinigungssystem	WaveClean nozzle
201147	Brausekopf	shower head
201160	Magnetventil 0,3-10 bar 5L/min	magnetic valve 0,3-10 bar 5L/min
202107	Auffangwanne	trip tray

## Spare part list HansDampf 6.1 / 6.2 / 10.1 / 10.2

202108	Tür-Auffangwanne	door-collecting tray
203028	Reedkontaktschalter	Reed contact switch
203279	Reihen клемме PE	terminal block
203325	Summer	buzzer
203442	Gleichrichter	rectifier
203473	Steuersicherung 6,3A T	control fuse 6,3A T
203667	Abdeckkappe Türverschuß	cap for door latch
203672	Hubmagnet	lift magnet
203673	Motor 400V 50-60Hz Schütz gesteuert	motor 400V 50-60 Hz contactor
203674	Begrenzer	safty temp. cut out
203675	Hauptschütz	main contactor
203676	Schütz hohe/ niedrige Drehzahl	contactor blower fan high/low speed
203678	Halogen-Lampenfassung	holder for halogen lighting
203679	Halogenlampe 20 W	halogen lighting 20 W
203680	WaveClean Pumpe 50Hz	WaveClean pump 50Hz
203682	Druckregler 3 bar incl. Manometer	pressure regulator 3 bar incl.
203683	RC - Kombination	RC - combination
203687	Durchflussmengenmesser	flow meter
203688	Kerntemperaturfühler	core temperature control probe
203689	Garraumfühler	chamber probe
203693	Wrasenfühler	drain probe
203695	RC - Kombination	RC - combination
203696	Hilfskontakt - Schütz	auxiliary contact
203697	Kerntemperaturfühler	core temperature control probe
203698	RC - Kombination	RC - combination
203720	Sicherung 0,8A T	control fuse 0,8A T
203723	Tastenkappe	push button cap
203724	Abstandsrolle	distancing bush
203733	Taster (Combi Pilot)	push button (CombiPilot)
203745	Tastaturplatine	key board
203746	Tastaturplatine	key board
203747	Leistungsplatine	power board
203748	Flash-Platine	flash modul
203765	Tastaturplatine + Leistungsplatine	key board + power board
203766	Tastaturplatine + Leistungsplatine	key board + power board
203771	Motor Frequenz gesteuert	motor frequency controlled
203784	Frequenzumrichter	frequency converter
203791	Magnetventil 0,3-10 bar 5L/min	magnetic valve 0,3-10 bar 5L/min
203800	Ferrit Ringkern	ferrite core
203971	Schütz Lüfter links/rechts	contactor blower fan left/right
203976	Motor 440V 50Hz	motor 440V 50Hz
203977	Motor 200V-230V 50Hz / 200V-240V 60Hz	motor 200V-230V 50Hz / 200V-240V
203985	Hauptschütz	main contactor
203987	Motor 200V-208V 50Hz / 200V-240V 60Hz	motor 200V-208V 50Hz / 200V-240V
203988	WaveClean Pumpe 60 Hz	WaveClean pump 60Hz
203990	Wrasenfühler	drain probe
203991	Fühler für Feuchtemessung	humidity probe
203996	Sicherung 10A T	fuse 10A T
204410	Schlauchaufroller	tube carrier
204416	Hebel für Wannenschluß	catch
204422	Belüfterdeckel 6.1	ventilation cap

## Spare part list HansDampf 6.1 / 6.2 / 10.1 / 10.2

204423	Arretierscheibe f. Wellendichtung	safty washer for shaft sealing
204425	Gerätefuß	adjustable foot
204428	Tülle für Schlauchbrause	spout tube shower
204430	Rohrleitung	pipe
205052	Reduziernippel R 1/2" - R 1/4"	reduction nipple R 1/2" - R 1/4"
205116	Reduziernippel R 3/4" - R 3/8"	reduction nipple R 3/4" - R 3/8"
205137	Verschlußschraube	locking screw
205171	Schlauchnippel	hose nipple
205172	Reduziernippel G 3/8" - G 1/8"	reduction nipple R 1/2" - R 1/4"
205173	Doppelnippel G 1/8"	double nipple G 1/8"
205175	Winkel R 1/8" - R 1/8"	bracket R 1/8" - R 1/8"
205176	Schlauchverschraubung	hose fitting
205179	Schlauchverschraubung	hose fitting
205181	Verteilerstück 2x 3/4" 2x 1/2"	distributor 2x 3/4" 2x 1/2"
205183	Fühlerverschraubung	probe screwing
205184	Verschraubung Garraumfühler	probe screwing
205188	Schlauchverschraubung	hose fitting
207089	Türgriff HansDampf	door handle HansDampf
207090	Verschlusskloben HansDampf	door catch
207091	Verschlusskloben HansDampf	door catch
207092	Türverschluss HansDampf	door latch HansDampf
207093	Schließzylinder	key cylinder
207094	Türverschluss HansDampf	door latch HansDampf
207097	Tastenkappe für Elektronik	cap for key
208032	Schlauchschele 5-7	hose fitting 5-7
208084	Schlauchschele 14,8 - 18	hose fitting 14,8 - 18
208086	Schlauchschele 61,8 - 65,0	hose fitting 61,8 - 65,0
209283	Klebeschild, MKN Logo	label, MKN logo
209295	Klebeschild Blau	label, blue
209296	Knebel für CombiPilot	knob for combi pilot
211077	Flachdichtung 121 x 163	seal 121 x 163
211078	Flachdichtung 73 x 73	seal 73 x 73
211079	Ringdichtung	ring seal
211080	Ringdichtung	sealing ring
211083	Flachdichtung für Heizkörper	seal for heating element
211084	Ringdichtung für Motorwelle	ring seal for motor shaft
211085	O-Ring Dichtung 3 x 2	sealing ring 3 x 2
211086	O - Ringdichtung	sealing ring
211087	Profildichtung Schalterblende	profil packing for front panel
211088	Profildichtung Schalterblende	profil packing for front panel
211089	Profildichtung Schalterblende	profil packing for front panel
211091	Dichtung	seal
211092	Dichtung	seal
211093	O-Ring Dichtung	sealing ring
211094	Türdichtung	door seal HansDampf
211095	Türdichtung	door seal HansDampf
211096	Türdichtung	door seal HansDampf
211097	Flachdichtung für Rohrleitung	seal for pipe
211098	Flachdichtung	seal
211101	Flach-Ringdichtung 5 x 69	seal 5 x 69
211103	Flachdichtung	seal

### Spare part list HansDampf 6.1 / 6.2 / 10.1 / 10.2

211111	Abdeckkappe	cap
214054	Flachringdichtung	seal
216217	Türrastvorrichtung oben	door extension arm, top
216218	Türrastvorrichtung unten	door extension arm, down
216273	Türbefestigung	door mount
216274	Türbefestigung	door mount
303025	Kleber	adhesive
574015	Heizkörper 30kW 230V	heating element 30kW 230V
574025	Heizkörper 30kW 254V	heating element 30kW 254V
574160	Heizkörper 9,9kW 230V	heating element 9,9kW 230V
574161	Heizkörper 20,4kW 230V	heating element 20,4kW 230V
574170	Heizkörper 9,9kW 208V	heating element 9,9kW 208V
574171	Heizkörper 9,9kW 254V	heating element 9,9kW 254V
574172	Heizkörper 15,6kW 208V	heating element 15,6kW 208V
574173	Heizkörper 20,4kW 254V	heating element 20,4kW 254V
801059	Abdeckplatte für Türverschluß	cover plate for latch
801064	Abdeckblech für Türverschluß	cover plate for latch
801074	Abdeckblech für Motor	cover plate for motor
801099	Abdeckplatte für Türverschluß	cover plate for latch
813436	Belüfter, Teil O	ventilation, part O
813441	Belüfter, Teil M	ventilation, part M
813446	Belüfter, Teil U	ventilation, part U
945344	Scheibe U 4,2	washer U 4,2
945414	Scheibe U26.7	washer U26.7
945446	Arretierscheibe für Motorwelle	safty washer motor shaft
960251	Türbefestigung	door mount
960382	Garraumtür	chamber door
960387	Garraumtür	chamber door
960392	Garraumtür	chamber door
960397	Garraumtür	chamber door
960426	Türbefestigung	door mount
960431	Türbefestigung	door mount
960456	Türbefestigung	door mount
960461	Türbefestigung	door mount
960516	Türbefestigung	door mount
960521	Türbefestigung	door mount
960532	Garraumtür	chamber door
960537	Garraumtür	chamber door

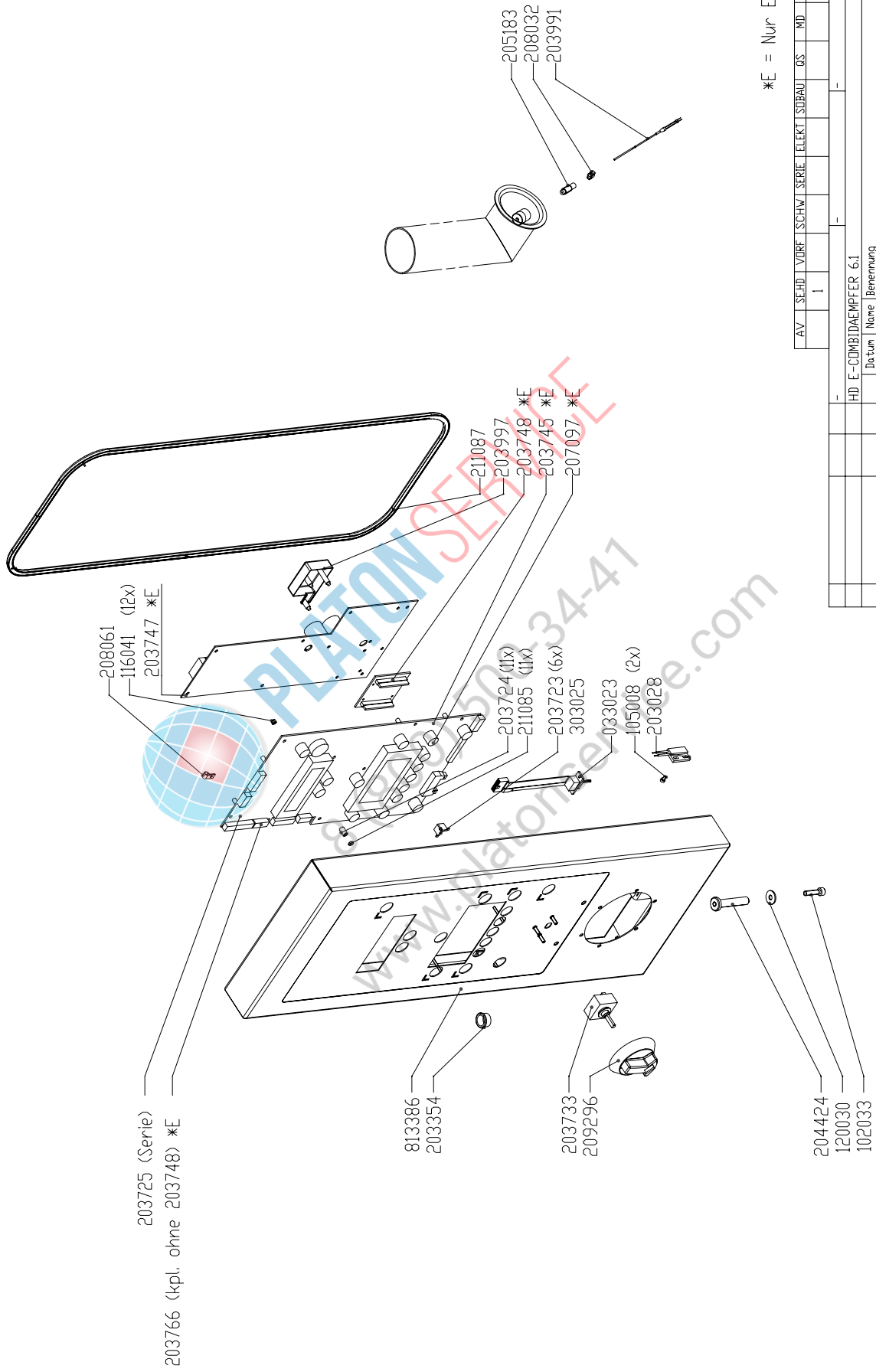

\*E = Nur Ersatzteil

AV	SE	HD	VORF	SCHW	SERIE	ELEKT	SUBBAU	QS	MD	KD	KB
HD E-COMBIDAEMPFER 6.1											
Datum		Benennung									
21.09.05		WTL									
Gez.		-									
Gepr.		-									
Frei.		-									
Resv.		-									
MKN		Modst. Zeichnungs Nr.									
CAD		15									
Toleranz		ISO 2768 - MK									
Änderung		-									
Ind.		-									
Blattzahl		813456--01ZE01X--									
Ers. d.		01									

Schalterblende HansDampf 6.1 Gold  
 Schalterblende HansDampf 6.2 Gold  
 front panel HansDampf 6.1 Gold  
 front panel HansDampf 6.2 Gold

Kapitel 7.2  
 chapter 7.2



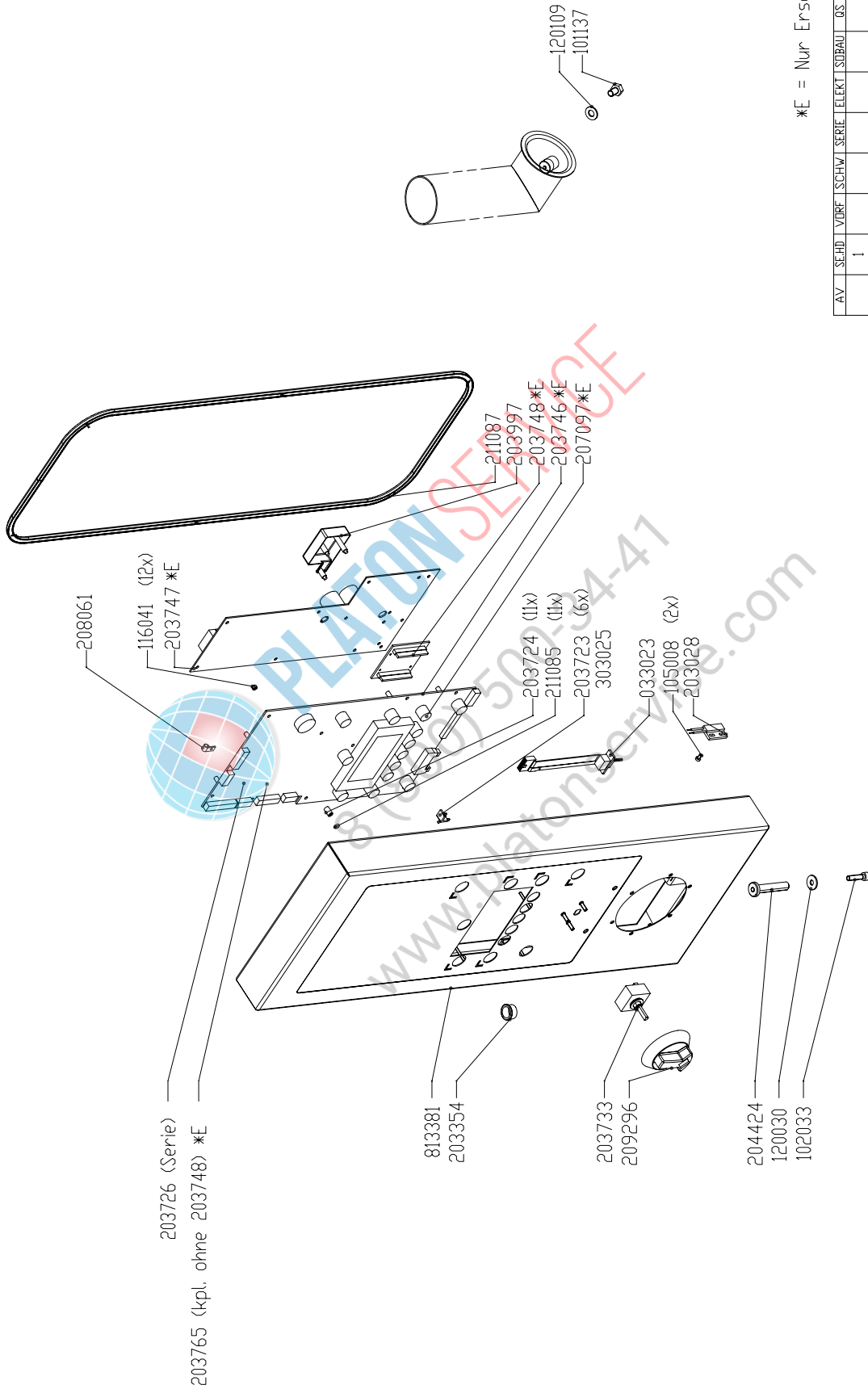

\*E = Nur Ersatzteil

AV	SE	HD	VORF	SCHW	SERIE	ELEKT	SUBBAU	QS	MD	KD	KB
HD E-COMBIDAEMPFER 6.1											
Datum		Benennung									
21.09.05		WTL									
Gepr.											
Frei.											
Resv.											
MKN		Molst. Zeichnungs Nr.									
CAD		15									
Toleranz		ISO 2768 - MK									
Änderung											
Blattzahl		813461--01ZE01X-									
Ers. d.		01									

Schalterblende HansDampf 6.1 Silver  
 Schalterblende HansDampf 6.2 Silver  
 front panel HansDampf 6.1 Silver  
 front panel HansDampf 6.2 Silver

Kapitel 7.2.1  
 chapter 7.2.1

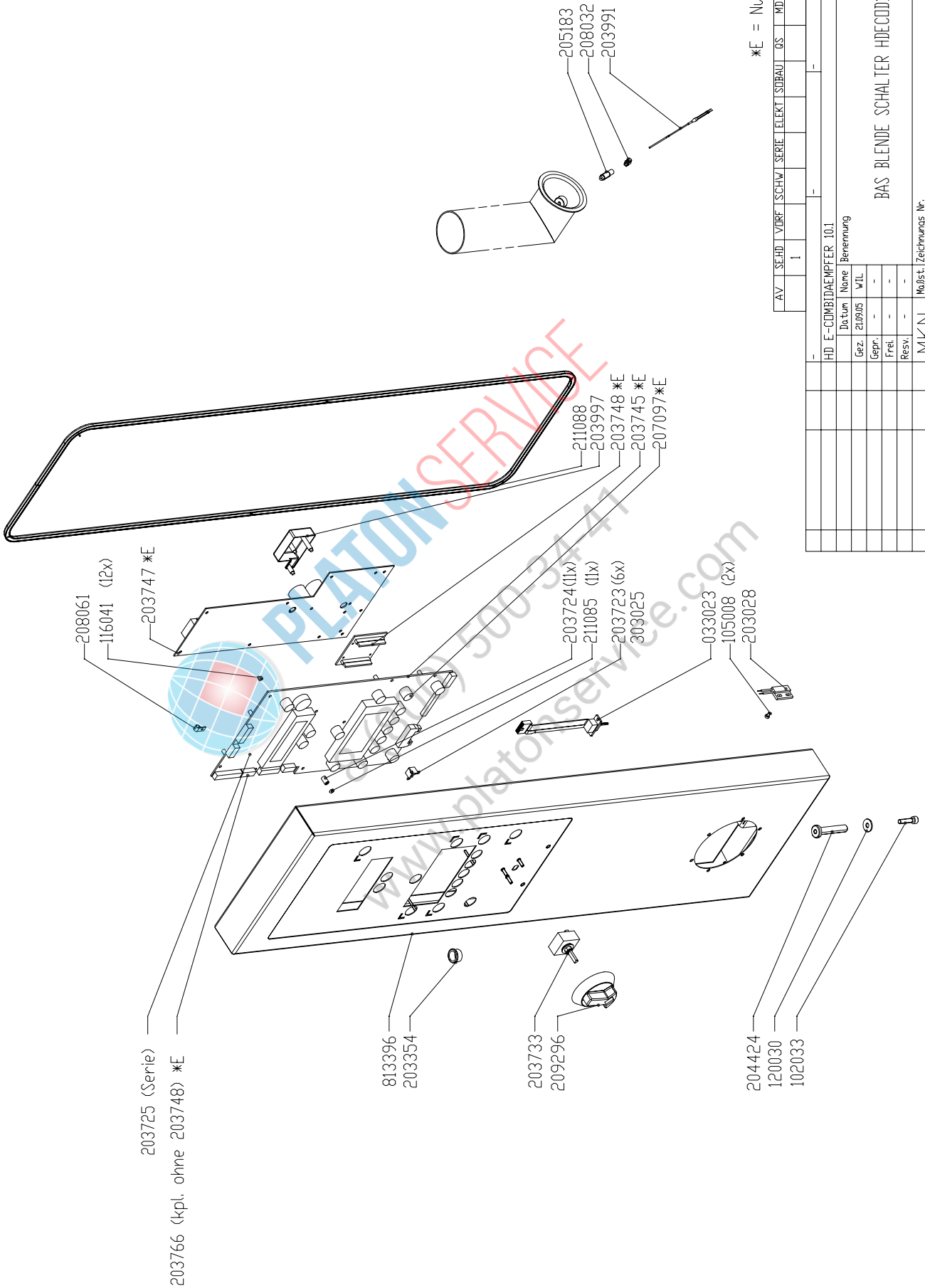

\*E = Nur Ersatzteil

AV	SE	HD	VORF	SCHW	SERIE	ELEKT	SUBBAU	QS	MD	KD	KB
	1									1	1

Datum	Name	Bemerkung
	HD E-COMBIDAEMPFER 10.1	
Gez.	21.09.05	WTL
Gepr.	-	-
Frei.	-	-
Resv.	-	-
MKN		MoJst. Zeichnungs Nr.
CAD	15	
		Blattzahl
		01

Incl.	Änderung	Datum	Name	Toleranz	ISO	2768	MK	Ers. f. -	Ers. d. -

BAS BLENDE SCHALTER HDECDD101 GOLD

813466--01ZE01X-

Schalterblende HansDampf 10.1 Gold  
 Schalterblende HansDampf 10.2 Gold  
 front panel HansDampf 10.1 Gold  
 front panel HansDampf 10.2 Gold

Kapitel 7.3  
 chapter 7.3



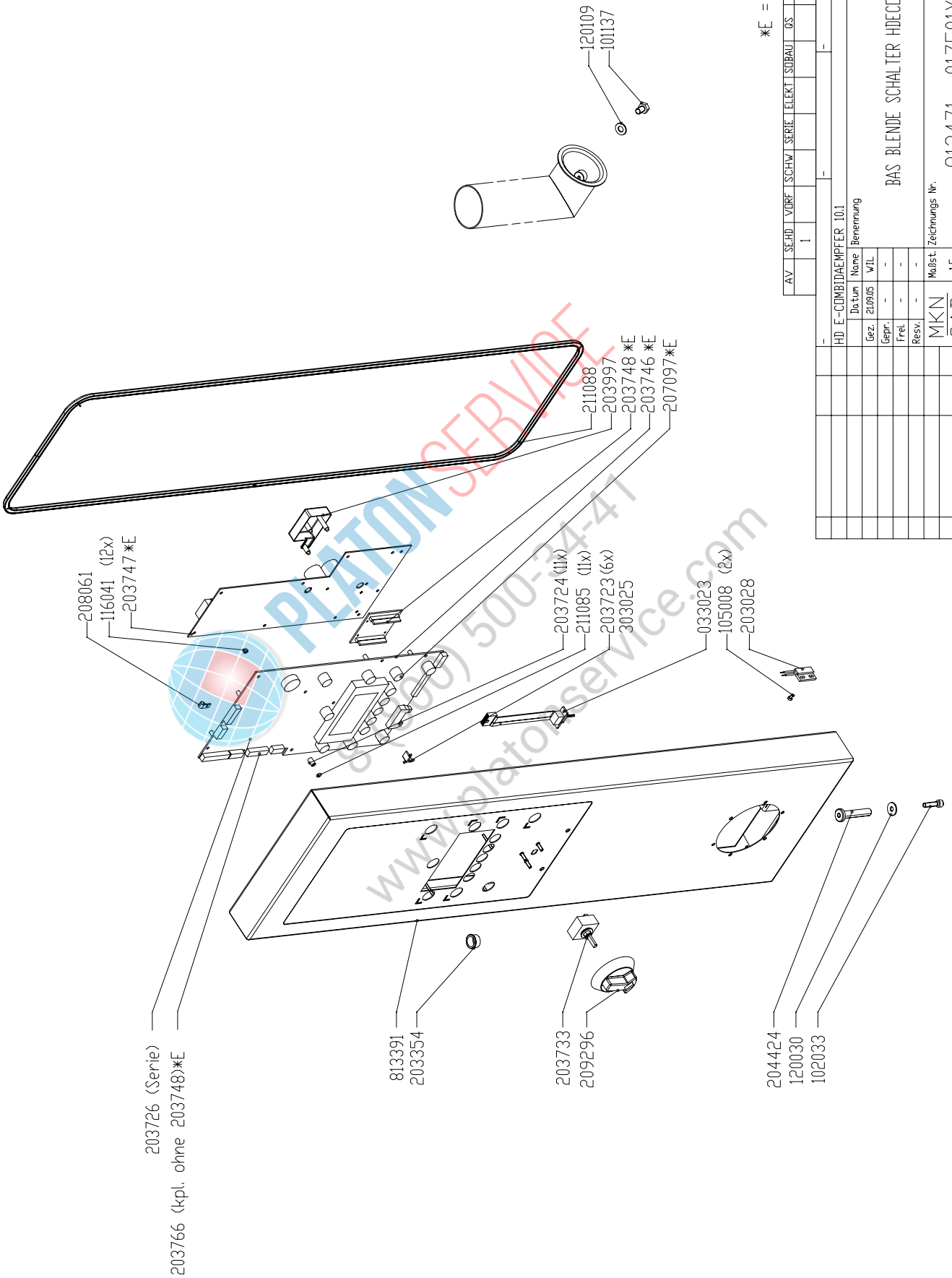

\*E = Nur Ersatzteil

AV	SE	HD	VORF	SCHW	SERIE	ELEKT	SUBBAU	QS	MD	KD	KB
1											1
HD E-COMBIDAEMPFER 10.1											
Datum		Benennung									
Gez.	21.09.05	WTL									
Gedr.	-	-									
Frei.	-	-									
Resv.	-	-									
MKN	Molst. Zeichnungs Nr.										
CAD	15	813471--01ZE01X-									
Toleranz		ISO 2768 - MK									
Incl.	Änderung	Datum	Name								
			Blattzahl								
			01								
Ers. f. -											Ers. d. -

Schalterblende HansDampf10.1 Silver  
 Schalterblende HansDampf10.2 Silver  
 front panel HansDampf 10.1 Silver  
 front panel HansDampf 10.2 Silver

Kapitel 7.3.1  
 chapter 7.3.1

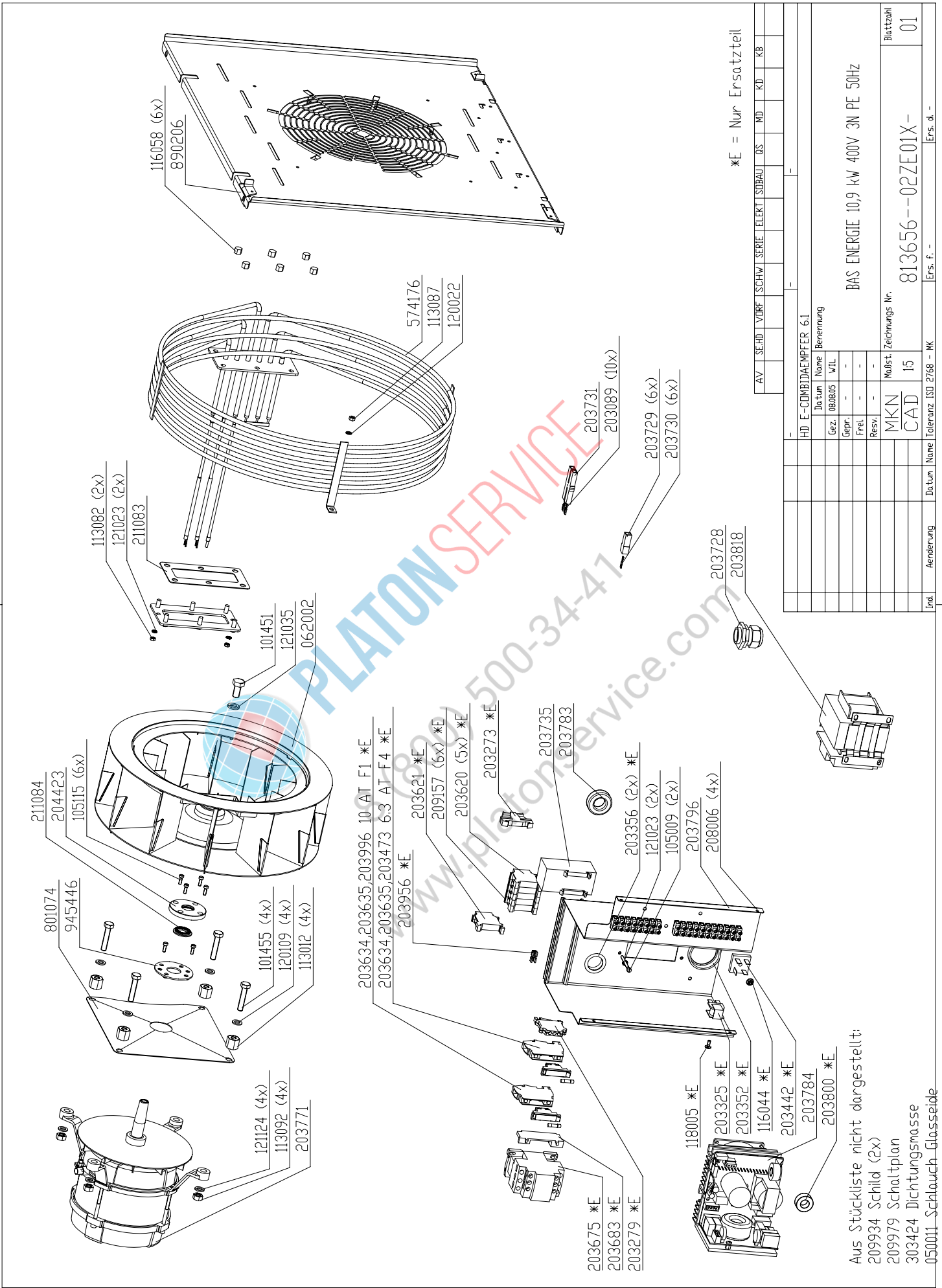

\*E = Nur Ersatzteil

AV	SE	HD	VORF	SCHW	SERIE	ELEKT	SUBBAU	QS	MD	KD	KB
HD E-COMBIDAEMPFER 6.1											
Datum		Name									
Gez.		08.08.05 WTL									
Gepr.											
Frei.											
Resv.											
MKN		Molst. Zeichnungs Nr.									
CAD		15									
Datei		Name									
Datei		Toleranz									
Datei		ISO 2768 - MK									
Datei		Ers. f. -									
Datei		Ers. d. -									
Datei		Blattzahl									
Datei		813656--02ZE01X-									
Datei		01									

Aus Stückliste nicht dargestellt:  
 209934 Schild (2x)  
 209979 Schaltplan  
 303424 Dichtungsmasse  
 050011 Schlauch Glasseite

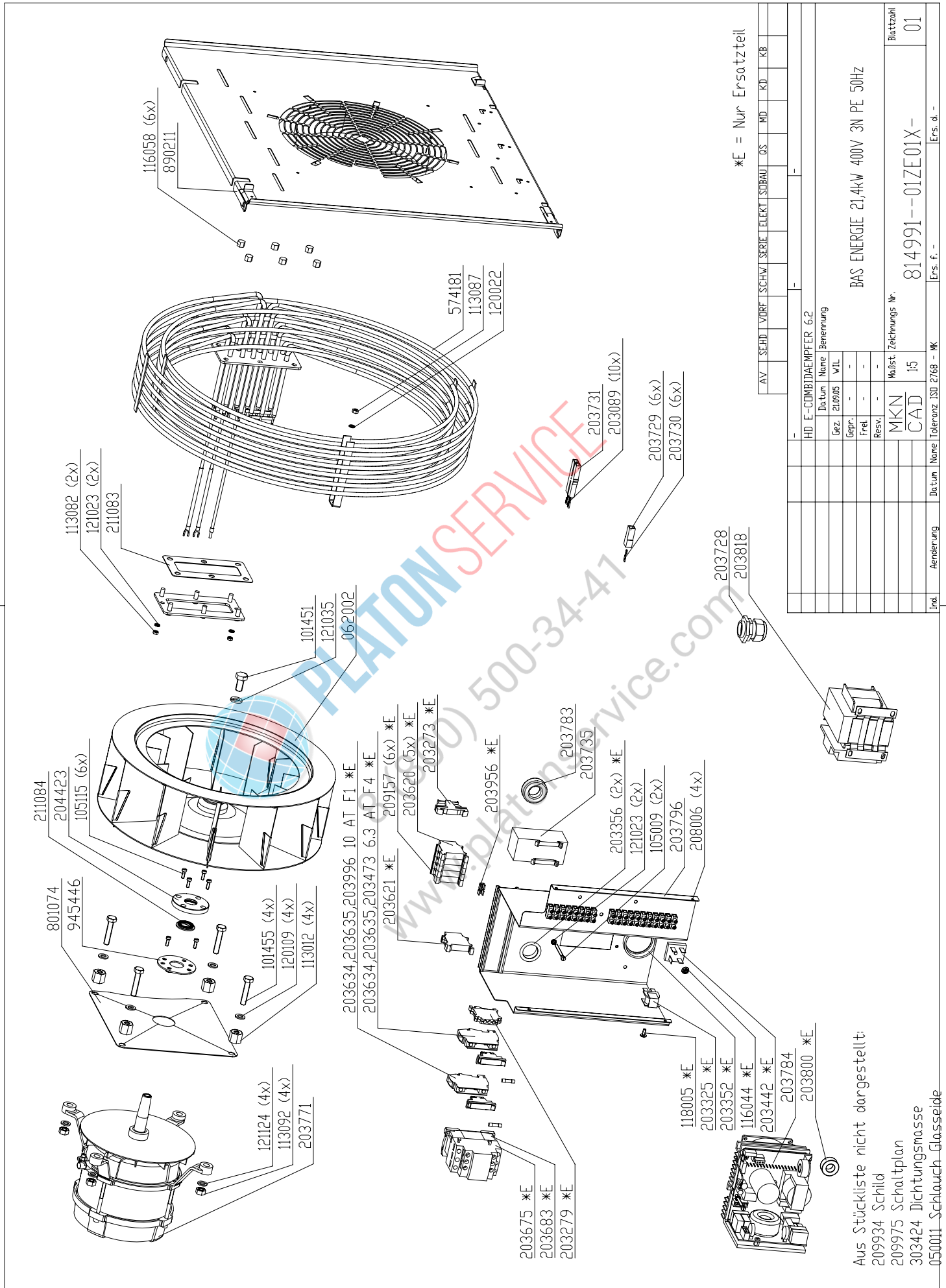

\*E = Nur Ersatzteil

AV	SE	HD	VORF	SCHW	SERIE	ELEKT	SUBBAU	QS	MD	KD	KB									
HD E-COMBIDAEEMPFER 6.2																				
Datum		Benennung																		
Gez.	21.09.05	WTL																		
Gepr.	-	-																		
Frei.	-	-																		
Resv.	-	-																		
MKN	Molst. Zeichnungs Nr.																			
CAD	15	814991--01ZE01X-																		
Incl.	Änderung	Datum	Name									Datum	Name	Toleranz	ISD	2768	-	MK	Ers. f. -	Ers. d. -

Aus Stückliste nicht dargestellt:  
 209934 Schild  
 209975 Schaltplan  
 303424 Dichtungsmasse  
 050011 Schlauch Glasseele

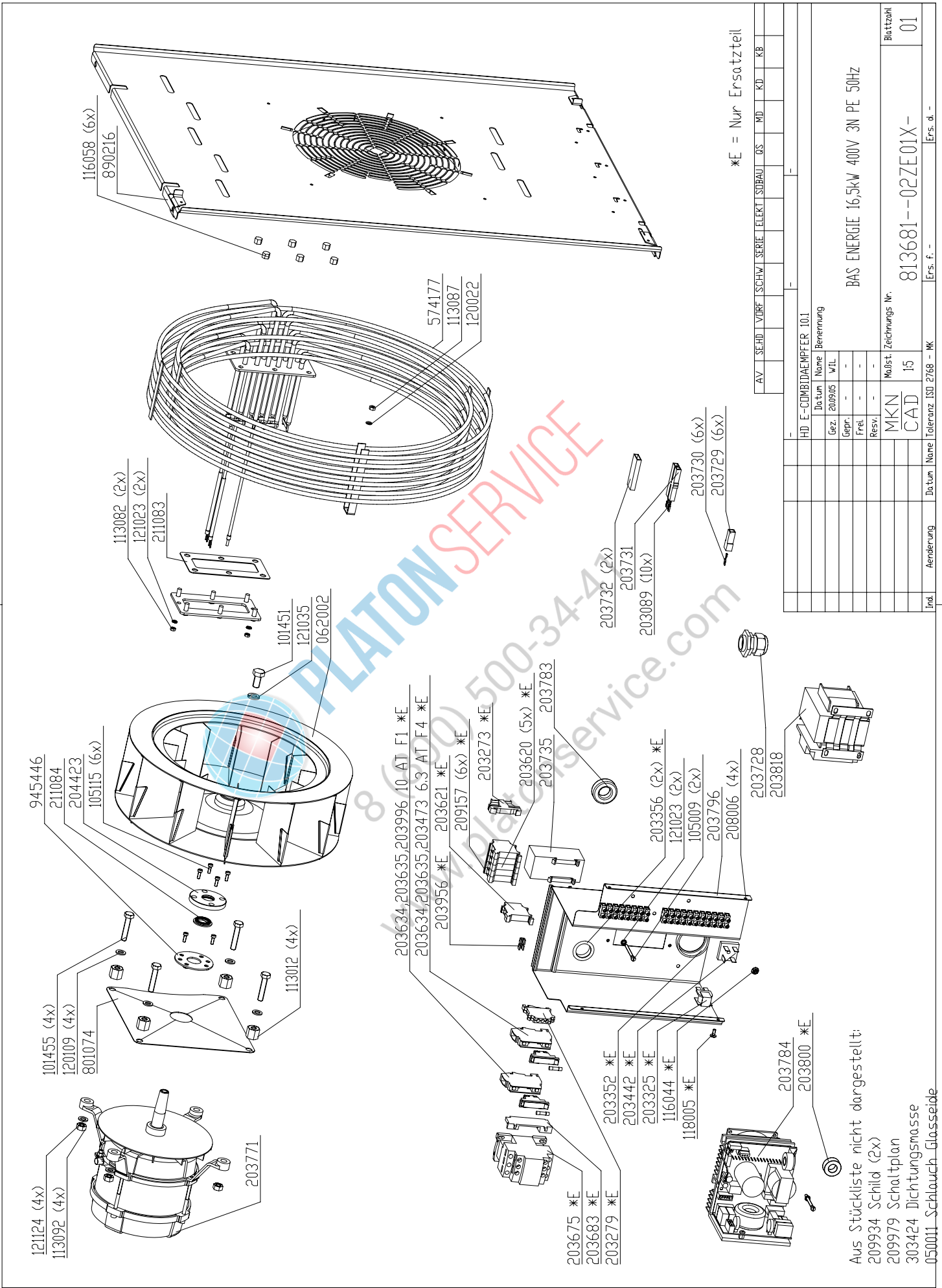

\*E = Nur Ersatzteil

AV	SE	HD	VORF	SCHW	SERIE	ELEKT	SUBBAU	QS	MD	KD	KB
HD E-COMBIDAEMPFER 10.1											
Datum		Benennung									
Gez.		WTL									
Gepr.											
Frei.											
Resv.											
MKN		Molst. Zeichnungs Nr.									
CAD		15									
Incl. Änderung		Datum Name Toleranz ISD 2768 - MK									
Ers. f. -		Ers. d. -									
Blattzahl		813681--02ZE01X-									
		01									

Aus Stückliste nicht dargestellt:  
 209934 Schild (2x)  
 209979 Schaltplan  
 303424 Dichtungsmasse  
 050011 Schlauch Glasseele

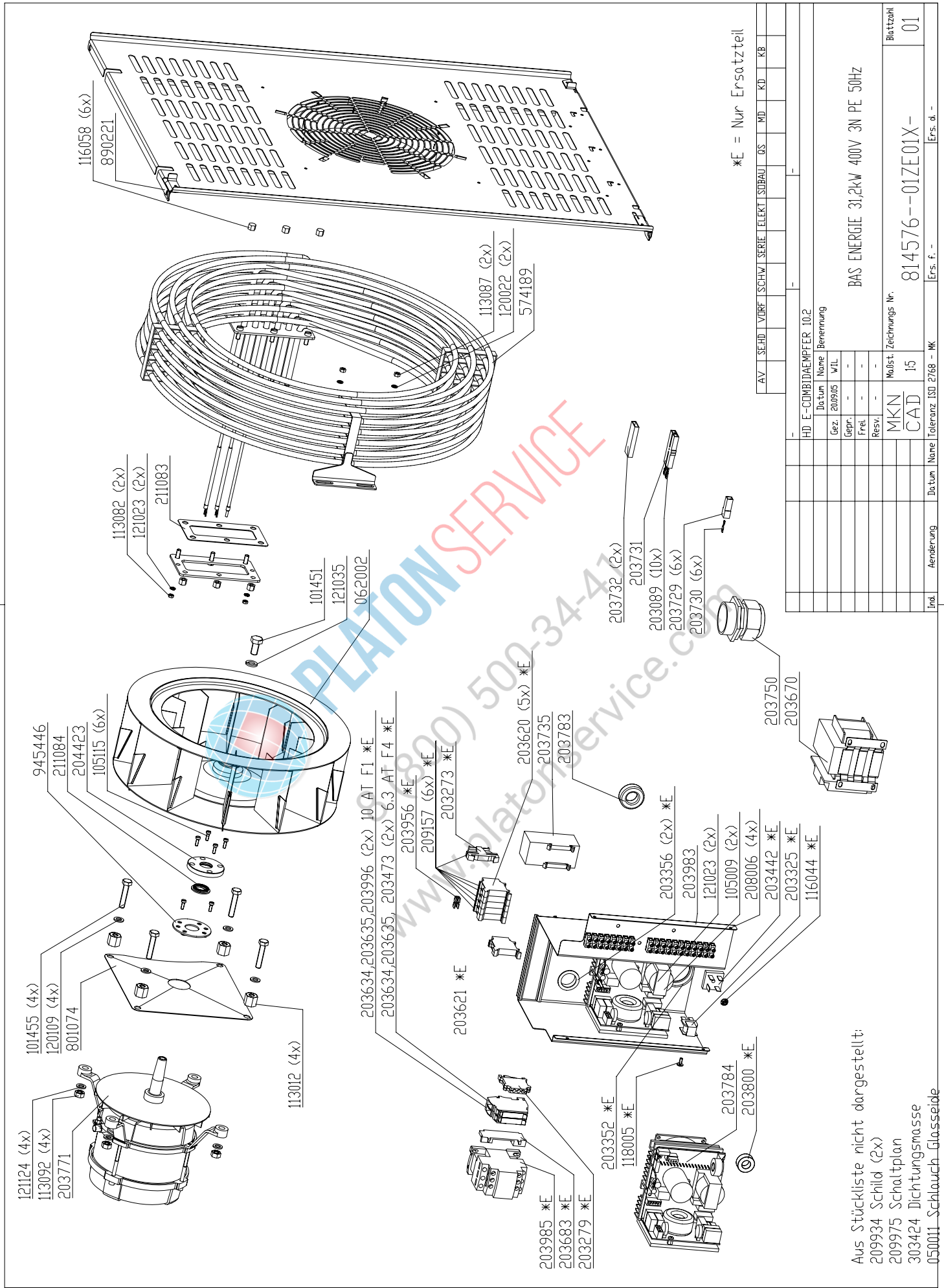

AV	SE	HD	VORF	SCHW	SERIE	ELEKT	SUBBAU	QS	MD	KD	KB
HD E-COMBIDAEMPFER 10.2											
Datum		Name									
Gez.		WTL									
Gegr.											
Fret.											
Resv.											
MKN		Molst. Zeichnungs Nr.									
CAD		15									
Ind.		Änderung		Datum		Name		Toleranz		ISO 2768 - MK	
BAS ENERGIE 31,2kW 400V 3N PE 50HZ											
										Blattzahl	
										814576--01ZE01X-	
										Ers. d. -	
										01	

Aus Stückliste nicht dargestellt:  
 209934 Schild (2x)  
 209975 Schaltplan  
 303424 Dichtungsmasse  
 050011 Schlauch Glasseite



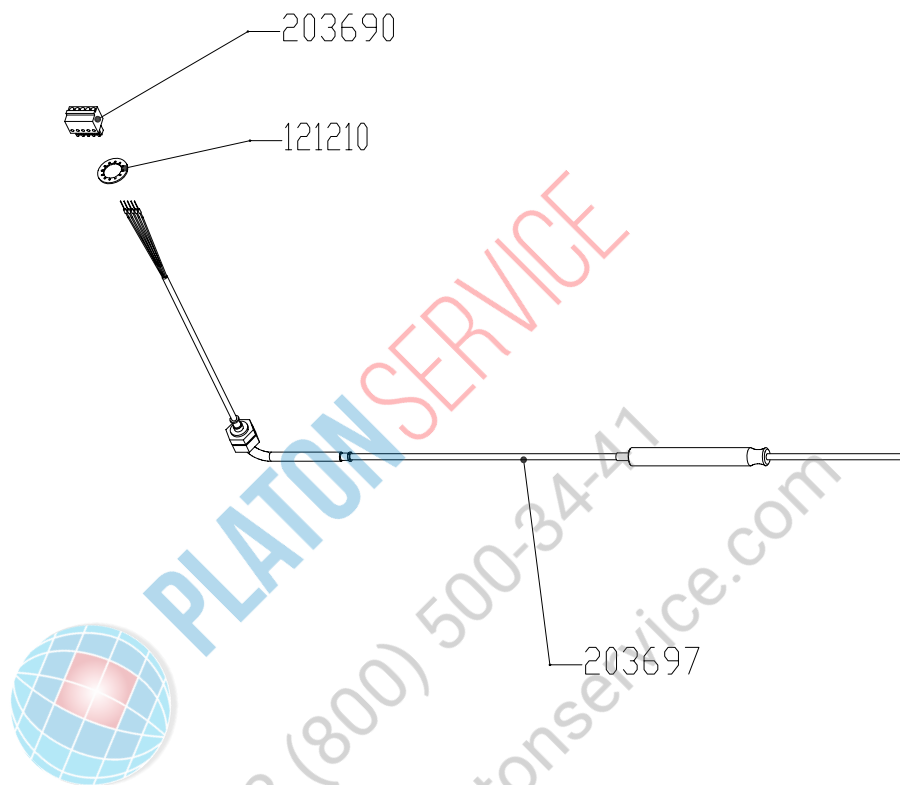

AV	SE.HD	VORF	SCHW	SERIE	ELEKT	SOBAU	QS	MD	KD	KB	
	1								1	1	

				-								
				HD E-COMBIDAEMPFER 6.1								
				Datum	Name	Benennung						
				Gez.	22.09.05	WIL	BAS FUEHLER HDECOD61 GOLD					
				Gepr.	-	-						
				Frei.	-	-						
				Resv.	-	-						
				MKN	Maßst.	Zeichnungs Nr.					Blattzahl	
				CAD	1:5	813601--00ZE01X-					01	
Ind.	Aenderung	Datum	Name	Toleranz ISO 2768 - MK				Ers. f. -			Ers. d. -	

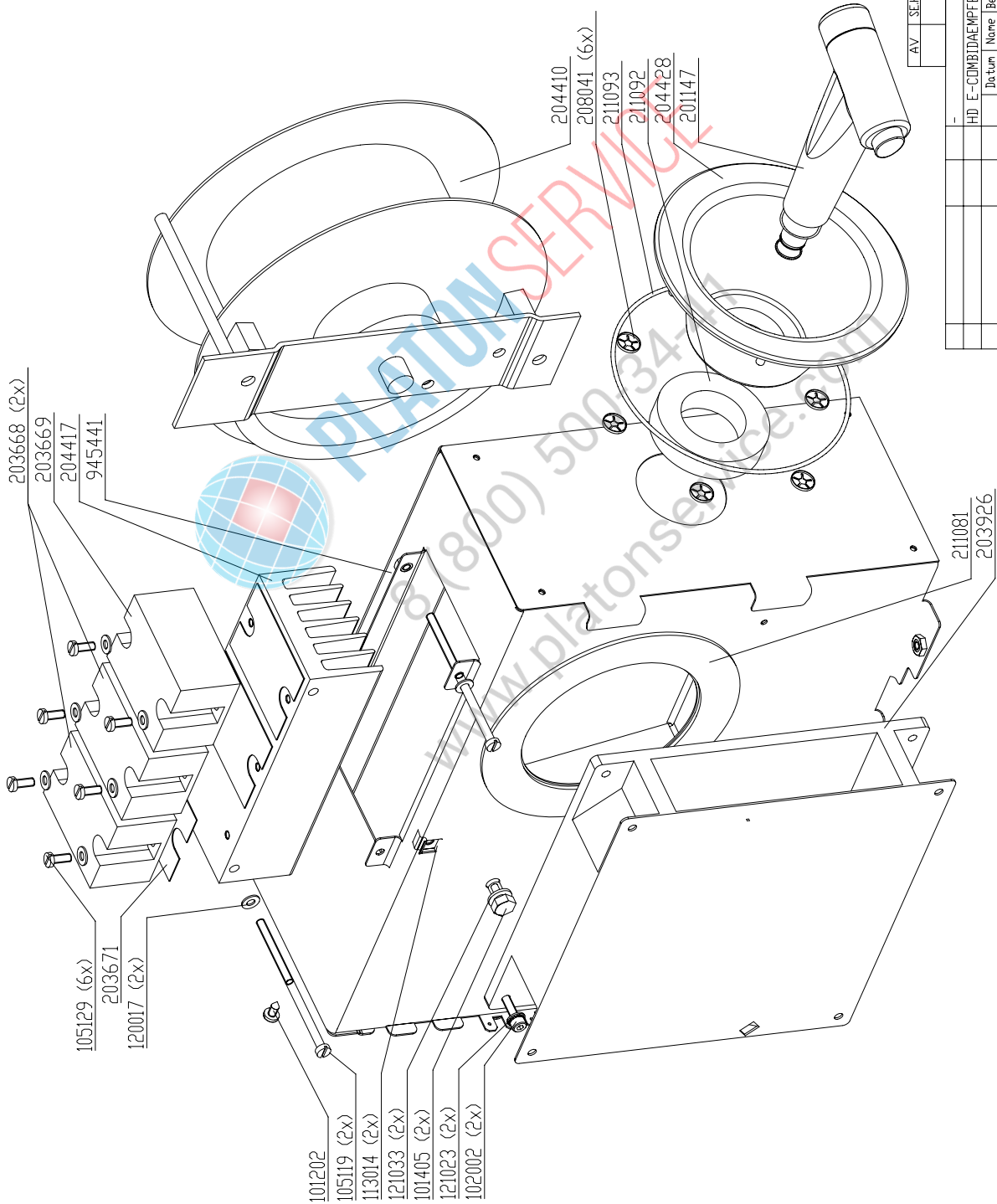

AV	SE	HD	VORF	SCHW	SERIE	ELEKT	SUBBAU	QS	MD	RD	KB
HD E-COMBIDAEMPFER 6.1											
Datum		Benennung									
Gez.	08.08.05	WTL									
Gepr.	-	-									
Fret.	-	-									
Resv.	-	-									
MKN	Molst. Zeichnungs Nr.										
CAD	1:2	813621--00ZE01X-									
Ind.		Änderung		Datum		Name		Toleranz		ISO 2768 - MK	
										Ers. d. -	
											Blattzahl
											01

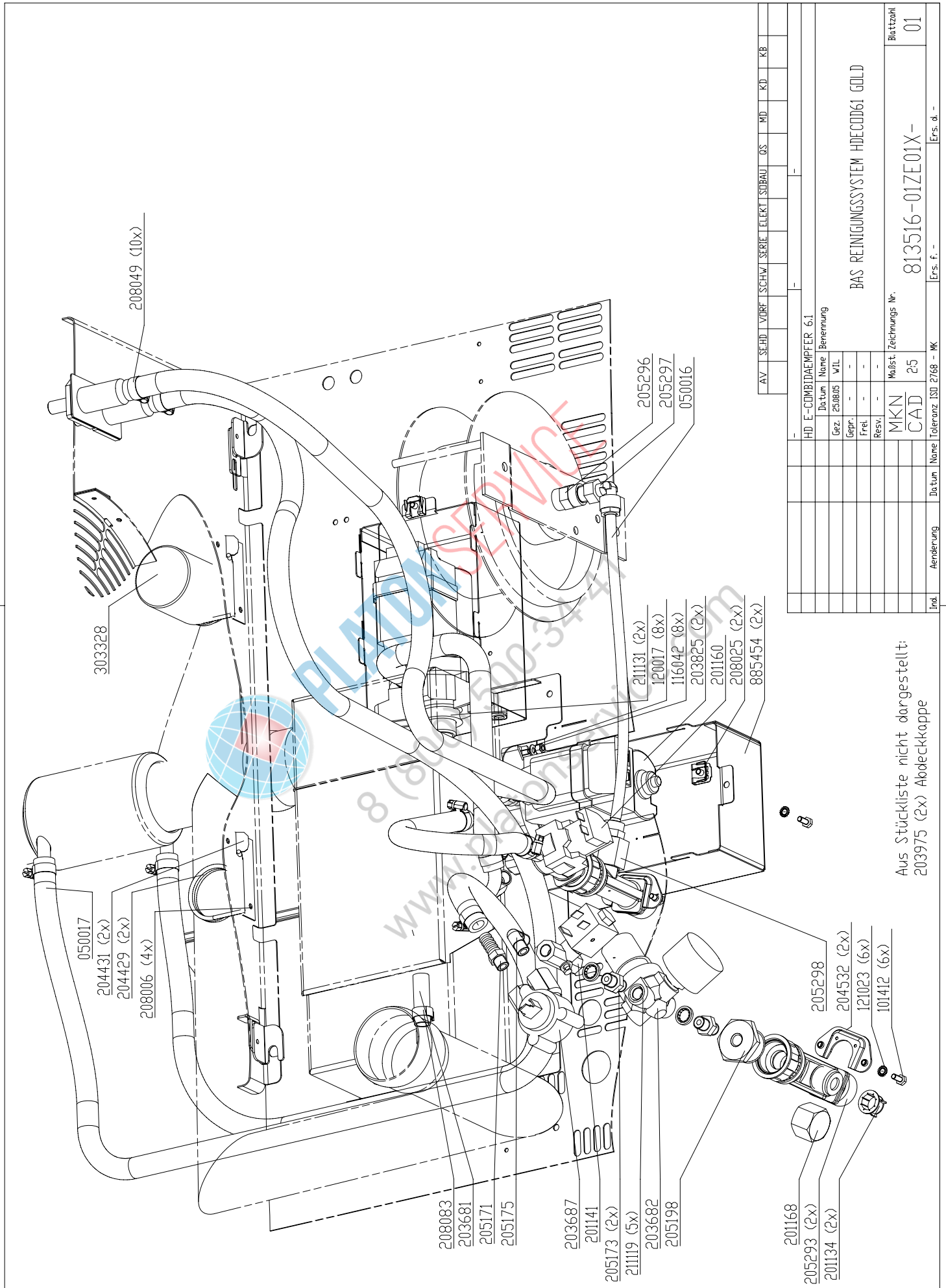

Wasserbaugruppe mit WaveClean  
water pipe assembly with WaveClean

AV	SE	HD	VORF	SCHW	SERIE	ELEKT	SUBBAU	QS	MD	KD	KB
HD E-COMBIDAEMPFER 6.1											
Datum		Benennung									
Gez.		WTL									
Gepf.											
Frei.											
Resv.											
MKN		Moist. Zeichnungs Nr.									
CAD		25									
Toleranz		ISO 2768 - MK									
Ers. f. -		813516-01ZE01X-									
Blattzahl		01									
Änderung											
Datum											
Name											
Incl.											

Aus Stückliste nicht dargestellt:  
203975 (2x) Abdeckkappe



208049 (6x)  
050017

208083 (3x)  
203681 (3x)

205171  
205175  
203687

201141  
203682  
211119 (5x)  
205173 (2x)  
205198  
205293 (2x)

201168  
201134 (2x)  
204532 (2x)  
121023 (6x)  
101412 (6x)

211132 (2x)  
801224 (2x)  
120017 (8x)  
116042 (8x)  
201160  
885449 (2x)  
205298  
208025 (2x)

205296  
205297  
050016

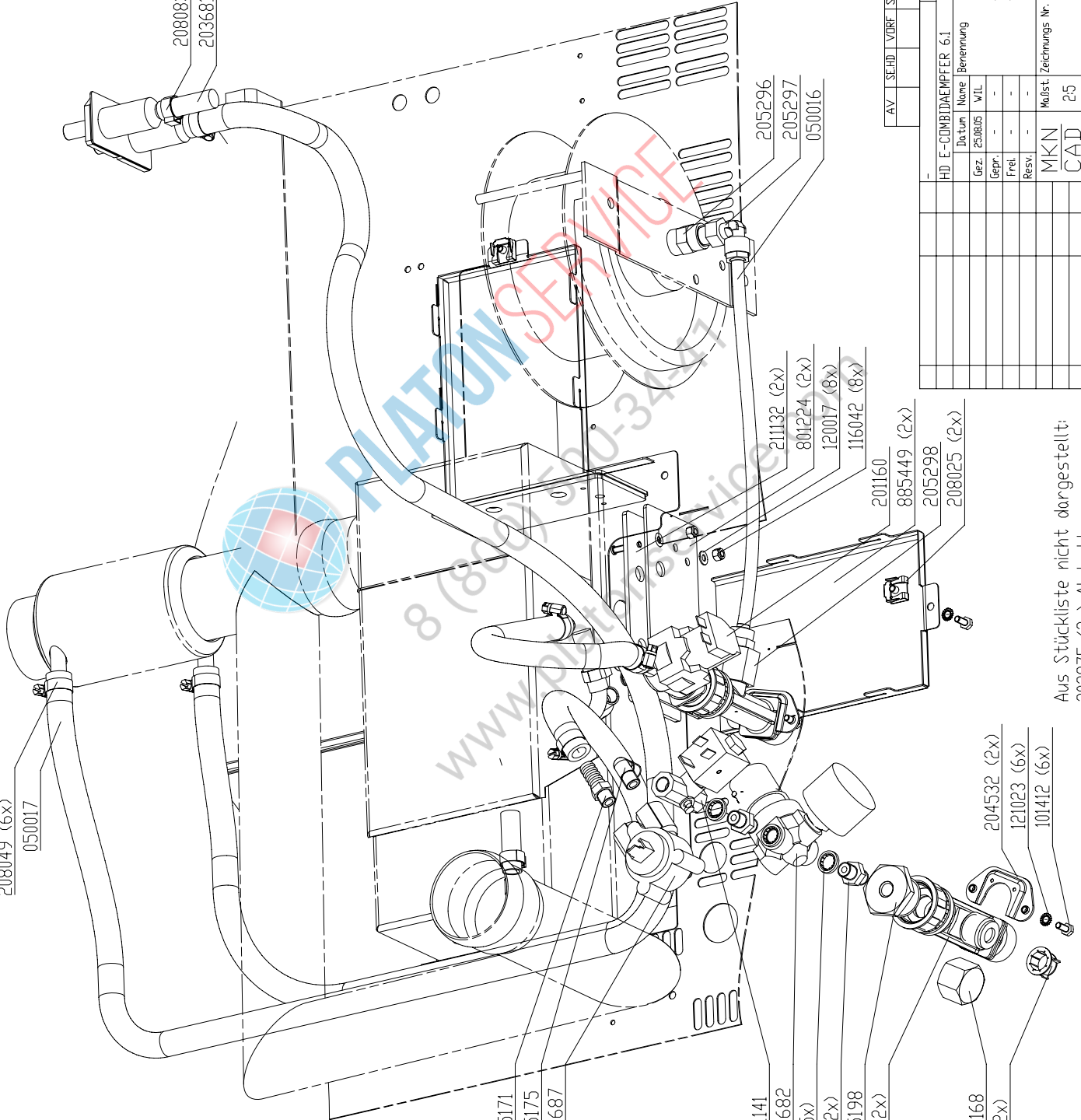

AV	SE	HD	VORF	SCHW	SERIE	ELEKT	SUBBAU	QS	MD	KD	KB
HD E-COMBIDAEMPFER 6.1											
Datum		Name									
Gez.		Benennung									
Gegr.		W/L									
Frei.											
Resv.											
MKN		Moist. Zeichnungs Nr.									
CAD		25									
Toleranz		ISO 2768 - MK									
Änderung											
Date		Date									
Name		Name									
Titel		Titel									
Blattzahl		Blattzahl									
01		01									
Ers. f.		Ers. f.									

Aus Stückliste nicht dargestellt:  
203975 (2x) Abdeckkappe

Aus Stückliste nicht dargestellt:

- 303021 Dichtungsbund
- 208006 Niet Blind (68x)
- 055123 Platte ISO
- 055124 Platte ISO
- 055126 Platte ISO
- 204427 Bolzen Schweiß (14x)
- 050011 Schlauch Glasseele
- 050012 Schlauch Glasseele
- 303019 Wärmeleitpaste
- 209090 Schild klebe
- 203734 Kabelbinder
- 305006 Palette
- 305008 Karton stuelp
- 911550 Profil links
- 911546 Profil rechts
- 866439 Halter
- 866434 Halter
- 208039 Mutter Blindniet (2x)

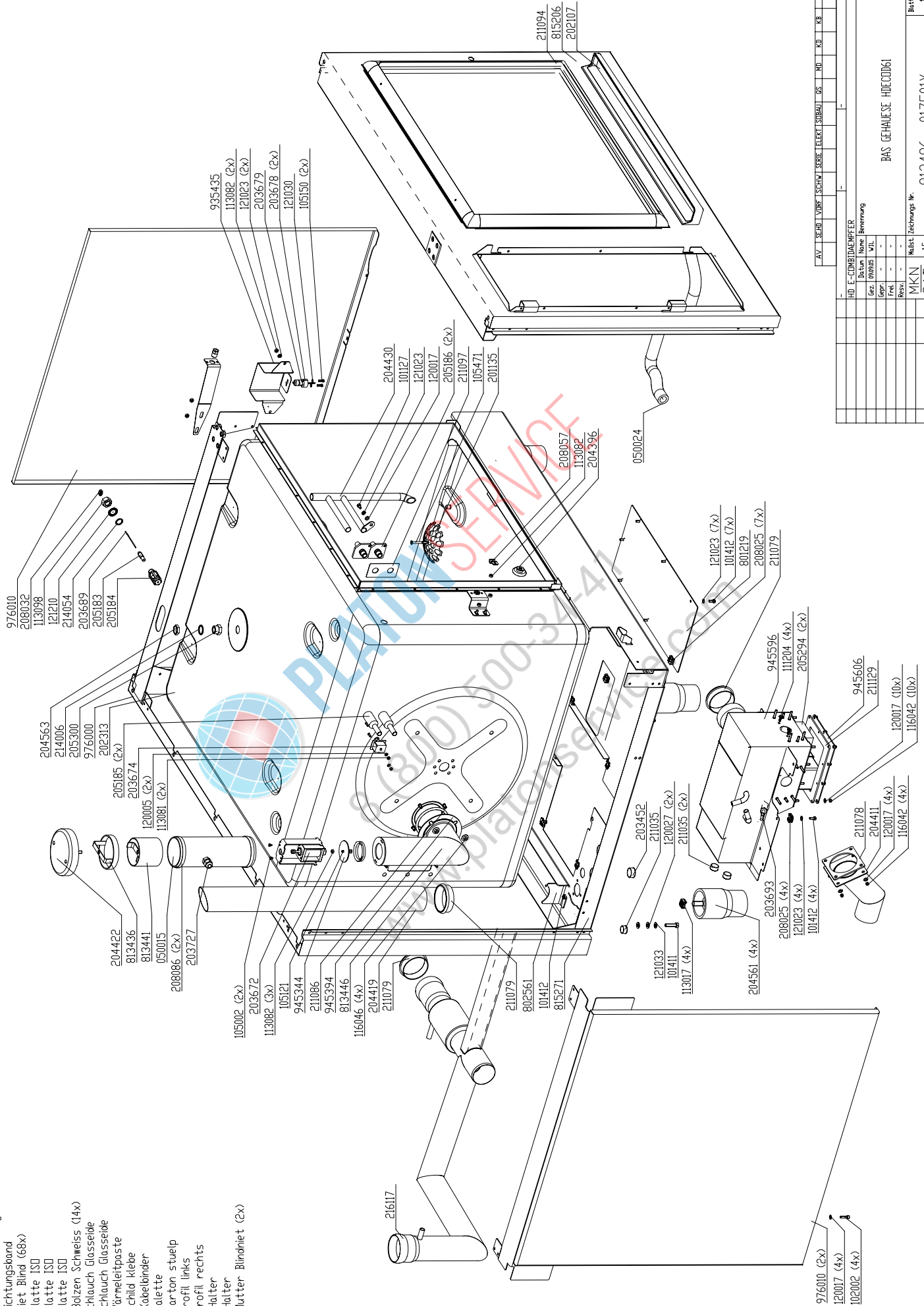

AV	SEHRT VORBE	ISCHWITZ	SEBET	TELEKT	SUBRAU	OS	MD	KD	K8
HD_E-COMBI/DAEMPFER									
Grz.	09/9/05	WIL							
Grp.	-	-							
Fret.	-	-							
Resv.	-	-							
MKN	MkSt. Zeichnungs-Nr.								
CAD	I5								
Änderung	Änd.	Nr.	Toleranz ISO 2768 - MK						
BAS GEHÄUSE HI/ECOD61									
813486--01ZE01X-									
Blattzahl 1									

Aus Stückliste nicht dargestellt:

- 303021 Dichtungsband
- 208006 Niet Blind (74x)
- 055123 Platte ISO
- 055124 Platte ISO
- 055127 Platte ISO
- 204427 Bolzen Schweiß (14x)
- 050011 Schlauch Glasseele
- 050012 Schlauch Glasseele
- 303019 Wärmeleitpaste
- 209090 Schild klebe
- 203734 Kabelbinder
- 305006 Palette
- 305008 Karton stuelp
- 911530 Profil links
- 911546 Profil rechts
- 866439 Halter
- 866434 Halter
- 208039 Mutter Blindniet (2x)

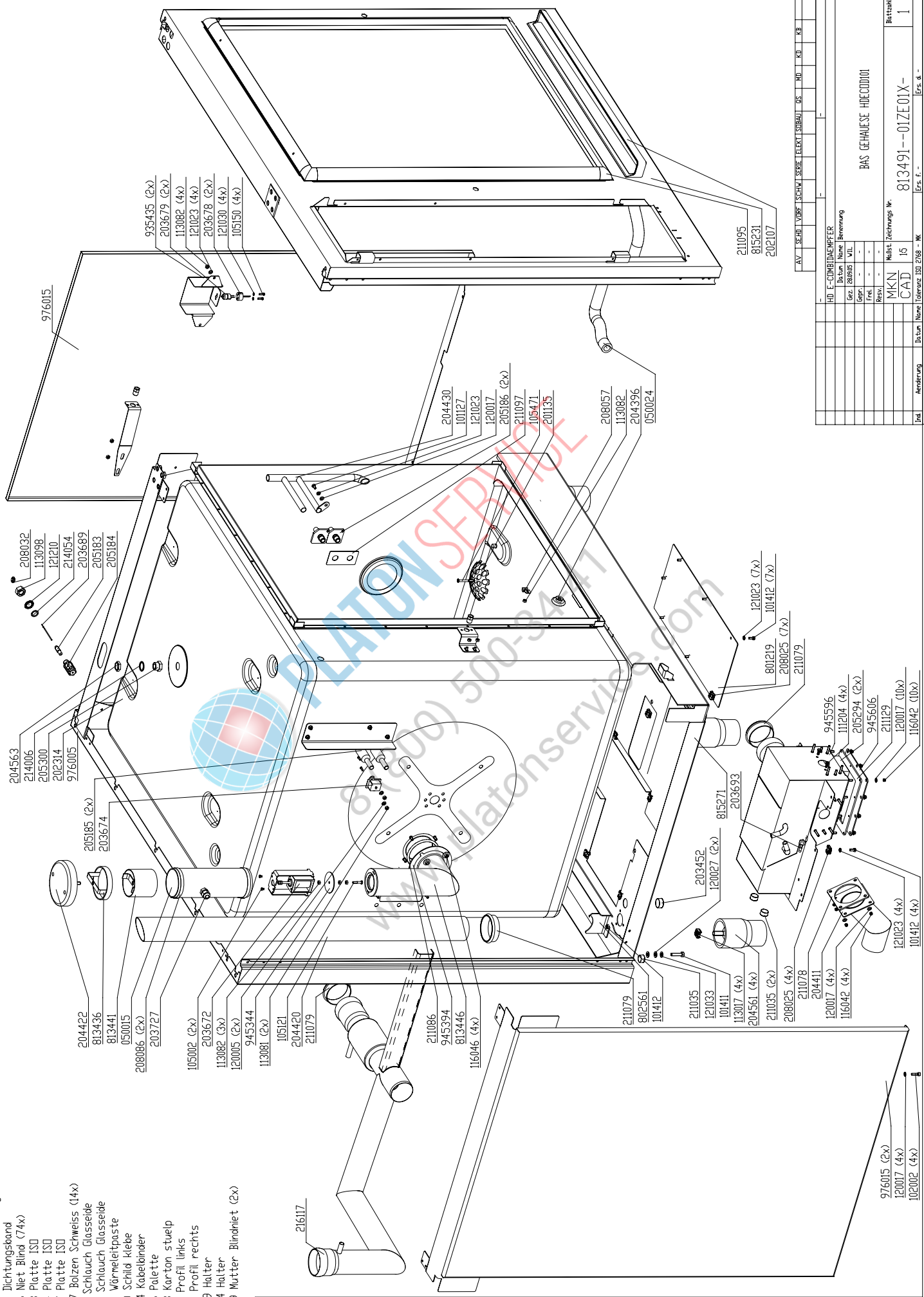

Gehäuse HansDampf 10.1 & 10.2  
chassis HansDampf 10.1 & 10.2

Kapitel 7.8.1  
chapter 7.8.1

AV	SEHRT VORBE	SCHWITZBLECHT	SUBRAU	ISO	MD	KD	K8																																																																																																
<table border="1"> <tr> <td>HD_E-COMBI</td> <td>DAEMPFER</td> <td></td> <td></td> <td></td> <td></td> <td></td> <td></td> </tr> <tr> <td>Best.Nr.</td> <td>Name</td> <td>Bemerkung</td> <td></td> <td></td> <td></td> <td></td> <td></td> </tr> <tr> <td>Grz.</td> <td>280905</td> <td>VIL</td> <td></td> <td></td> <td></td> <td></td> <td></td> </tr> <tr> <td>Lager</td> <td>-</td> <td>-</td> <td></td> <td></td> <td></td> <td></td> <td></td> </tr> <tr> <td>Resv.</td> <td>-</td> <td>-</td> <td></td> <td></td> <td></td> <td></td> <td></td> </tr> <tr> <td>MkSt.</td> <td>MKN</td> <td>Ziehungs-Nr.</td> <td></td> <td></td> <td></td> <td></td> <td></td> </tr> <tr> <td>CAD</td> <td>15</td> <td></td> <td></td> <td></td> <td></td> <td></td> <td></td> </tr> <tr> <td>Best.Nr.</td> <td>813491</td> <td>15</td> <td></td> <td></td> <td></td> <td></td> <td></td> </tr> <tr> <td>Toleranz</td> <td>ISO 2768 - MK</td> <td></td> <td></td> <td></td> <td></td> <td></td> <td></td> </tr> <tr> <td>Änderung</td> <td></td> <td></td> <td></td> <td></td> <td></td> <td></td> <td></td> </tr> <tr> <td>Entf.</td> <td></td> <td></td> <td></td> <td></td> <td></td> <td></td> <td></td> </tr> <tr> <td>Blattzahl</td> <td>1</td> <td></td> <td></td> <td></td> <td></td> <td></td> <td></td> </tr> </table>								HD_E-COMBI	DAEMPFER							Best.Nr.	Name	Bemerkung						Grz.	280905	VIL						Lager	-	-						Resv.	-	-						MkSt.	MKN	Ziehungs-Nr.						CAD	15							Best.Nr.	813491	15						Toleranz	ISO 2768 - MK							Änderung								Entf.								Blattzahl	1						
HD_E-COMBI	DAEMPFER																																																																																																						
Best.Nr.	Name	Bemerkung																																																																																																					
Grz.	280905	VIL																																																																																																					
Lager	-	-																																																																																																					
Resv.	-	-																																																																																																					
MkSt.	MKN	Ziehungs-Nr.																																																																																																					
CAD	15																																																																																																						
Best.Nr.	813491	15																																																																																																					
Toleranz	ISO 2768 - MK																																																																																																						
Änderung																																																																																																							
Entf.																																																																																																							
Blattzahl	1																																																																																																						
BAS GEHÄUSE HDECD001																																																																																																							
<table border="1"> <tr> <td>Entf.</td> <td>813491</td> <td>15</td> <td></td> <td></td> <td></td> <td></td> <td></td> </tr> <tr> <td>Blattzahl</td> <td>1</td> <td></td> <td></td> <td></td> <td></td> <td></td> <td></td> </tr> </table>								Entf.	813491	15						Blattzahl	1																																																																																						
Entf.	813491	15																																																																																																					
Blattzahl	1																																																																																																						

\*E = Nur Ersatzteil

AV	SEHRT VORF	SCHW	TELEKT	SIBRAU	OS	MD	LD	KD	KB
HD_E-CUMBIENAMPFERZ 6.1									
	Dist	Num	Benennung						
Grz	68805	WIL							
Ggr:	-	-							
Resv:	-	-							
MkSt:	MKN	Zeichnungs-Nr.							
CAD	I5	813541--01ZE01X-							
Ind	Amendierung	Dist	Num	Nov	Termin	Bsp. 2/88 - MK			
						Ers. d. -			

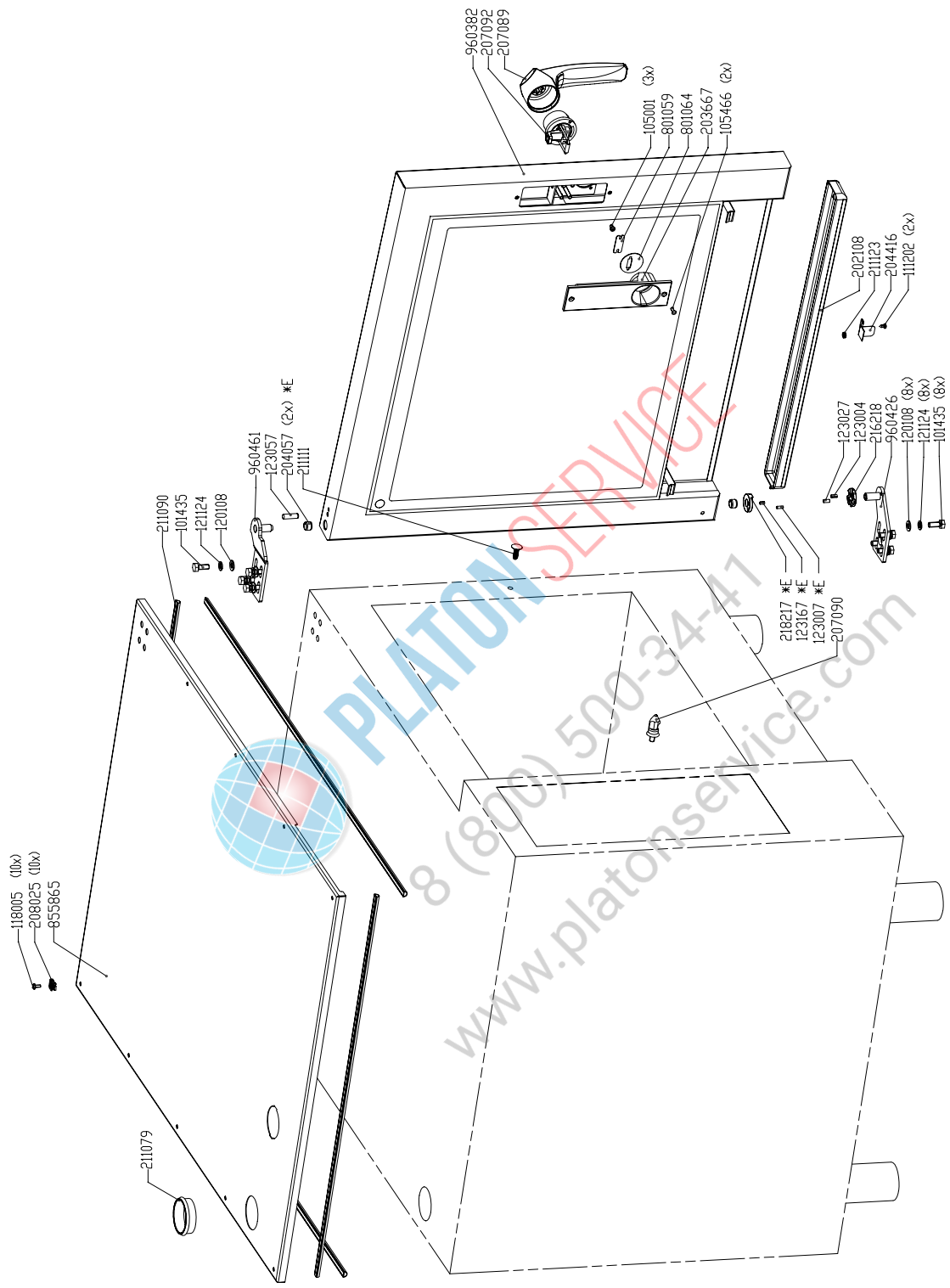

Gehäuse Türbereich HansDampf 6.1 & 6.2 Rechtsanschlag  
chassis door area HansDampf 6.1 & 6.2 right hand hinged

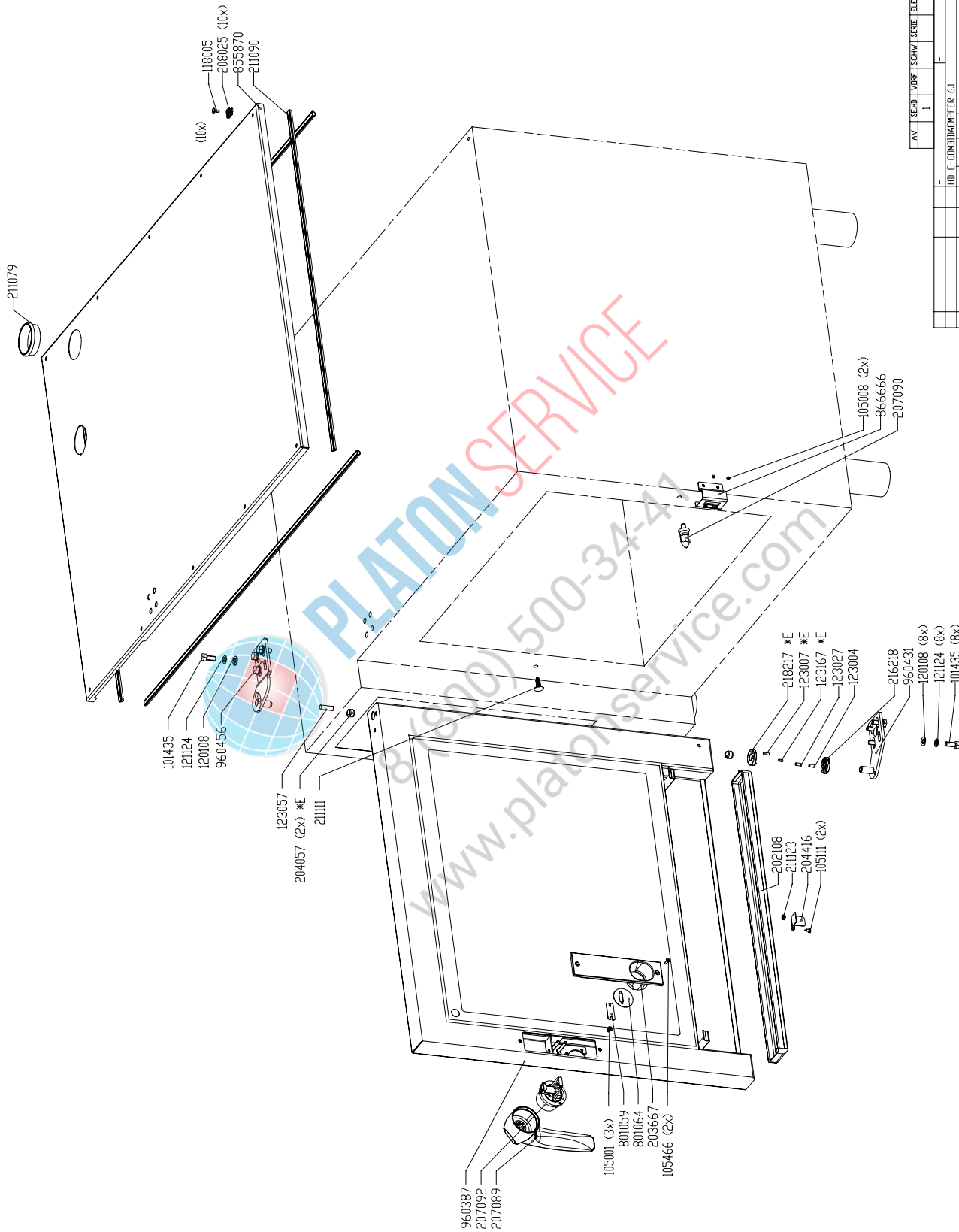

\*E = Nur Ersatzteil

AV	SEHRT	VORF	SCHW	TELEKT	SUBRAU	OS	MD	LD	KD	KB
HD_E-CUMBIEDAMPFER 6.1										
Grz.	698805	WIL								
Grp.	-									
Frei.	-									
Resv.	-									
MKN	MkSt. Zeichnungs-Nr.									
CAD	I5									
Änderung	Dis. tun	None	Toleranz 100, 200 - MK							
Ind.	Ers. f. -									
BAS TÜR HÖE0061 LI										Blattzahl
813551--01ZE01X-										01
										Ers. d. -

Aus Stückliste nicht dargestellt:  
 813501 Liftzplan  
 203268 Klemme Lwester

Gehäuse Türbereich HansDampf 6.1 & 6.2 Linksanschlag  
 chassis door area HansDampf 6.1 & 6.2 left hand hinged

Kapitel 7.9.1  
 chapter 7.9.1

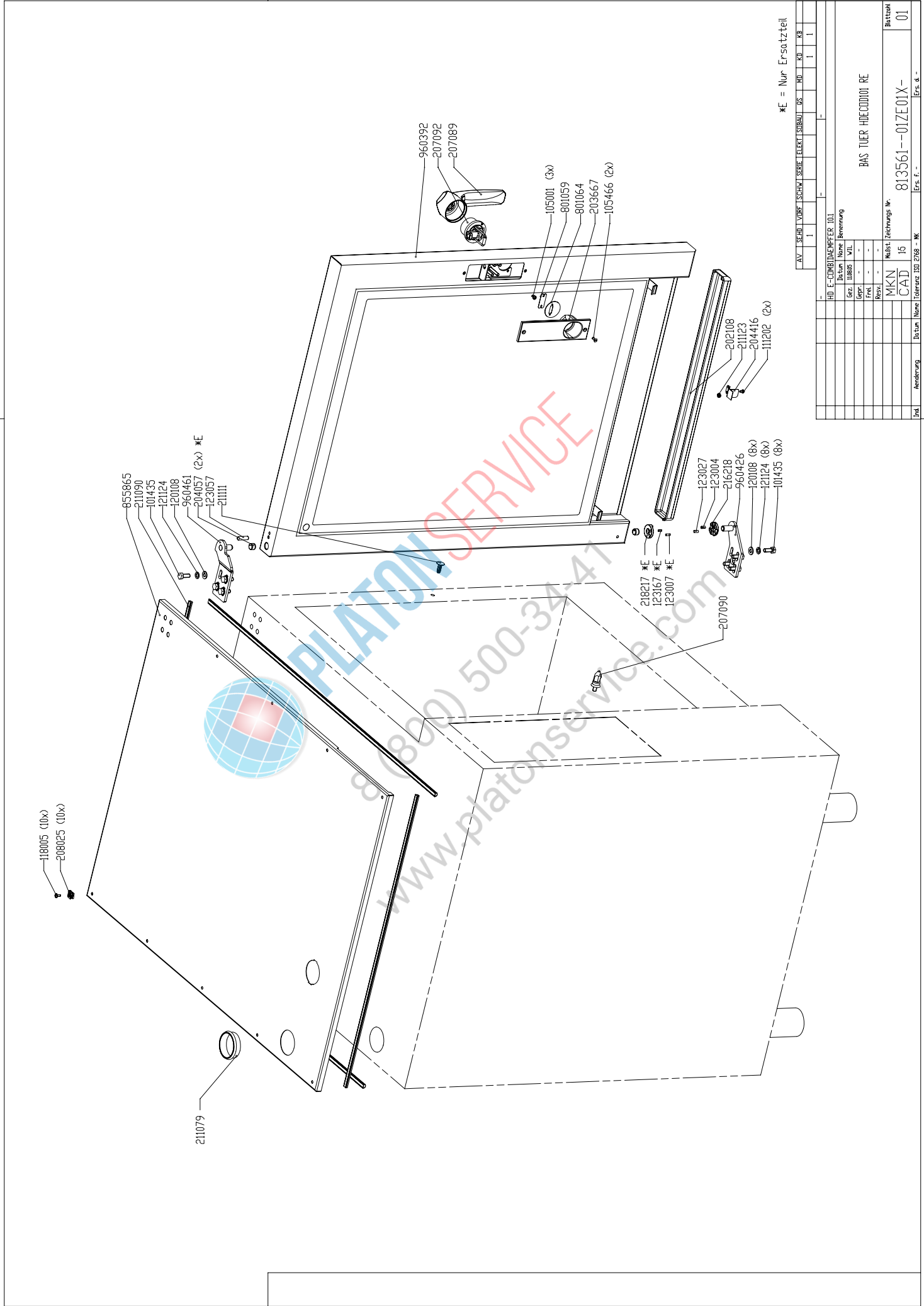

\*E = Nur Ersatzteil

AV	SEHRT VORRE	SCHWEL	SEBET	TEKERT	SUBRAU	OS	MD	KD	K8
HD_E-CUMBUAEPFEZ 101									
Grz.	118805	WIL							
Ggr.	-	-							
Resv.	-	-							
MkSt.	MKN	MkSt. Zeichnungs-Nr.							
CAD	15	813561--01ZE01X-							
Ind.	Änderung	Distun	Nome	Toleranz	ISO 2768 - MK	Ers. f. -			
						Ers. d. -			

BAS TUER HIDECD0101 RE

Blattzahl

01

Gehäuse Türbereich Hans Dampf 10.1 & 10.2 Rechtsanschlag  
 chassis door area Hans Dampf 10.1 & 10.2 right hand hinged

Kapitel 7.9.2  
 chapter 7.9.2



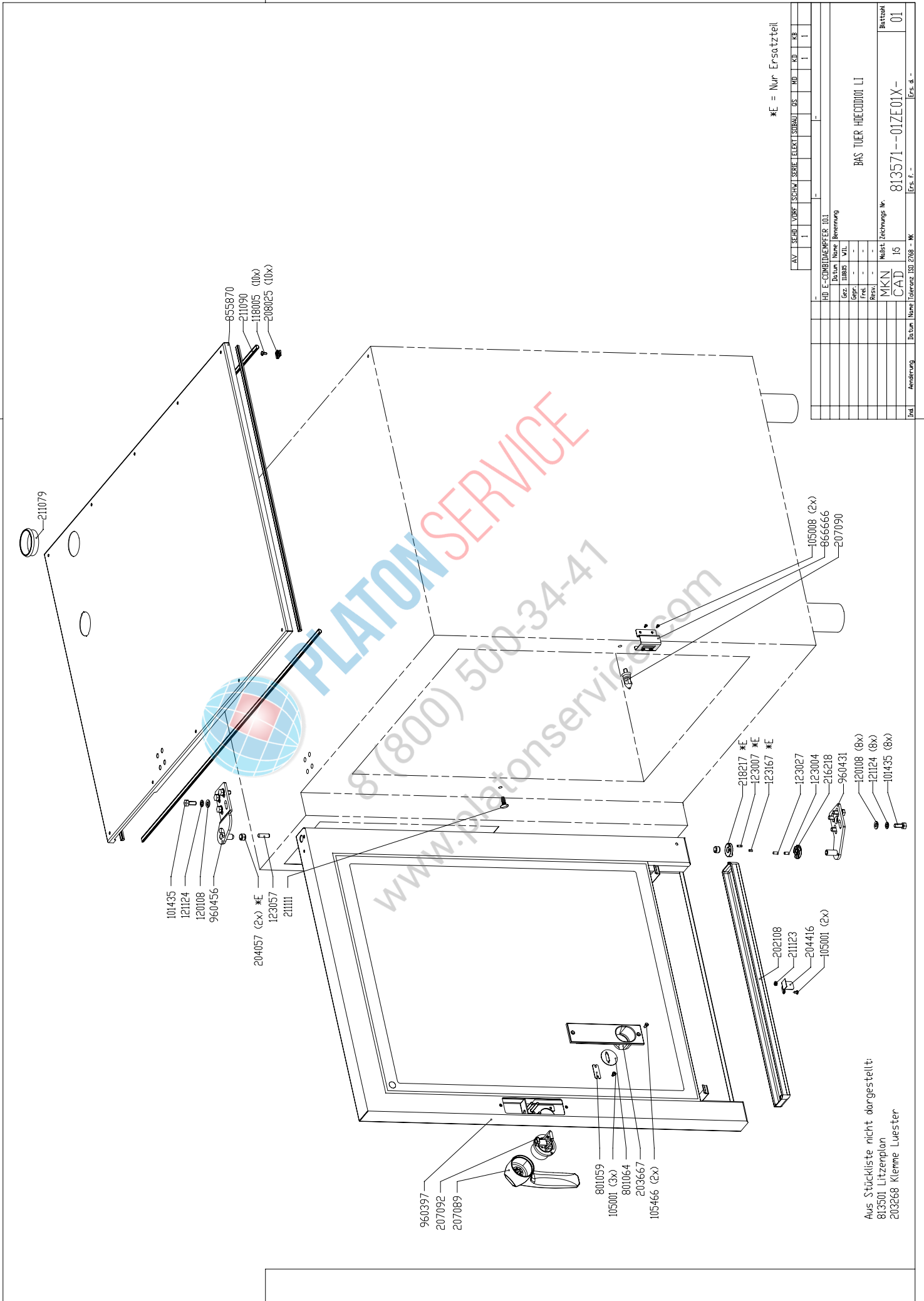

Gehäuse Türbereich HansDampf 10.1 & 10.2 Linksanslag  
chassis door area HansDampf 10.1 & 10.2 left hand hinged

Kapitel 7.9.3  
chapter 7.9.3

\*E = Nur Ersatzteil

AV	SEHRT	VORF	SCHW	TELEKT	SIBRAU	OS	MD	KD	K8

HD	E	COMB	DAMPFER	101

Grz.	11805	VIL

Resv.		MkSt.	Zerchnungs Nr.

Ind.	Änderung	Datum	Name	Telefon	BSD	2765	MK	Ers. g.

BAS TÜR HIDECD001 LI

813571--01ZE01X-01

Aus Stückliste nicht dargestellt:  
813501 Litztenplan  
203268 Klemme Lwester